

Bi-static and Multi-static Sensing in Wireless Communication Networks: Technologies and Applications

J. Andrew Zhang

Prof on Wireless Signal Processing
Global Big Data Technologies Centre

<https://sites.google.com/view/andrewzhang/>

ELLIIT Focus Period Symposium
Linköping University, Sweden
April 2026

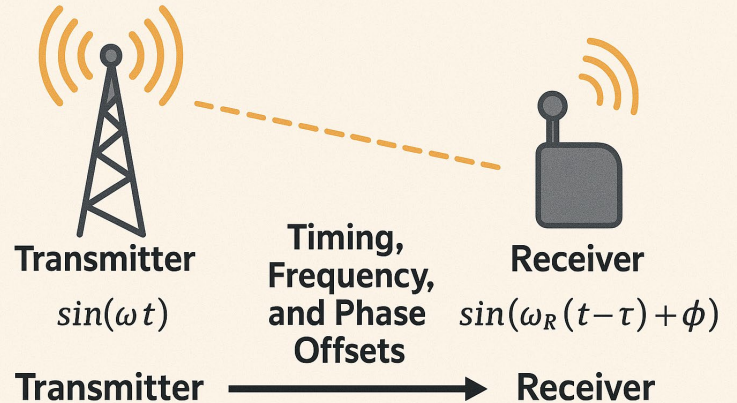

UTS:
ENGINEERING AND
INFORMATION
TECHNOLOGY

Outline

- Background
- Bi-static Sensing: Existing Single-node Solutions and Open research problems
- Multi-static Sensing
- Our Exemplified Projects
 - Environmental sensing: Water level and rainfall intensity
 - WiFi sensing for smart home: safety, security and automation
- Concluding Remarks

Integrate Sensing into Communications

- Integrated Sensing and Communications (ISAC, aka, JCAS)
- Integrate radio/radar sensing into (any) communications networks via mainly software implementation: Foundation technologies of many next-generation networks (802.11bf, 6G).

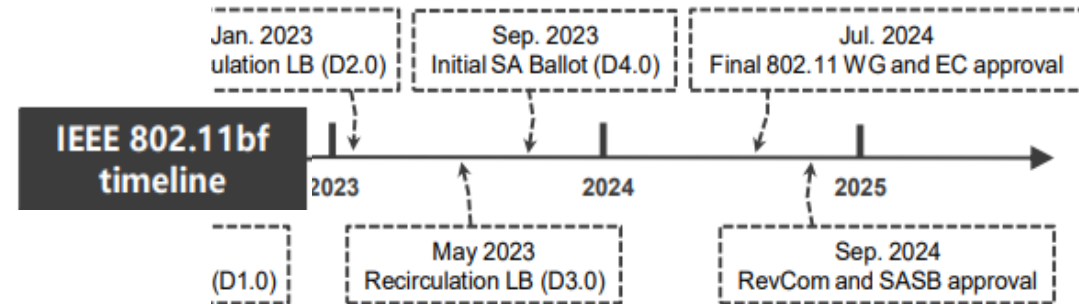
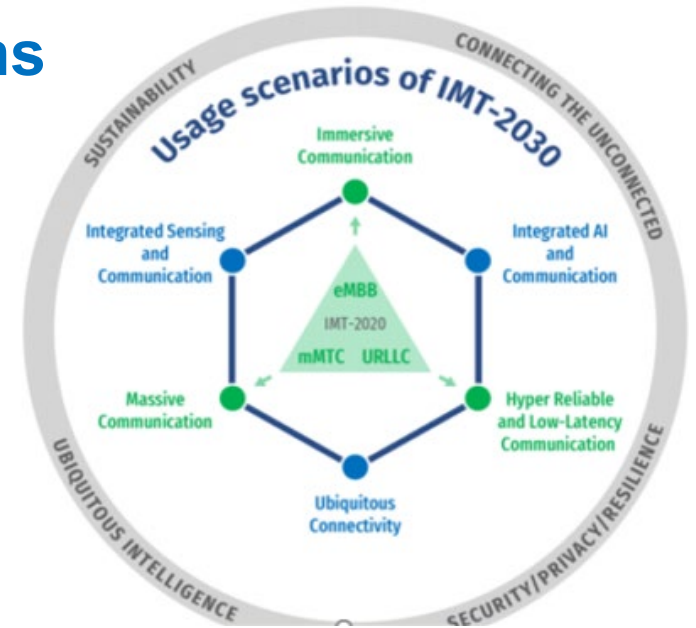

UTS Radio Sensing and Pattern Analysis (RaSPA) Lab

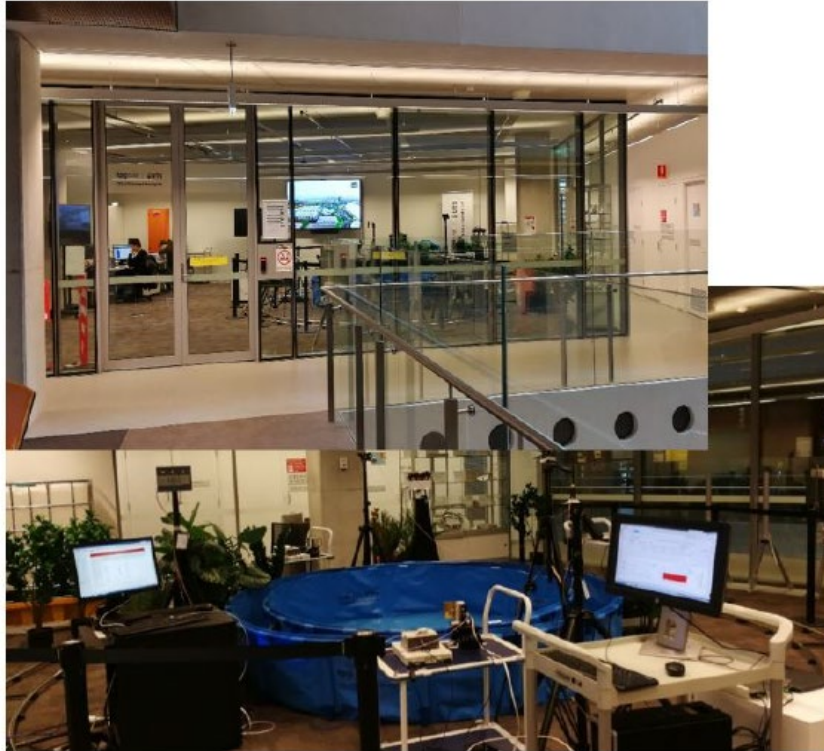

UTS RaSPA is a pioneering leader in ISAC R&D worldwide (started research in 2016).

- First monograph ISAC book, and 70+ top journal publications, highly cited papers
- \$8M+ research funding and 9 projects since 2018
- A 5-year Network-Sensing Joint Research Lab with mobile operator TPG
- Leadership in international ISAC communities

Our ISAC Platforms

mmWave transceiver



Antenna array and SDRs customised for 5G flood sensing



WiFi sensing platform

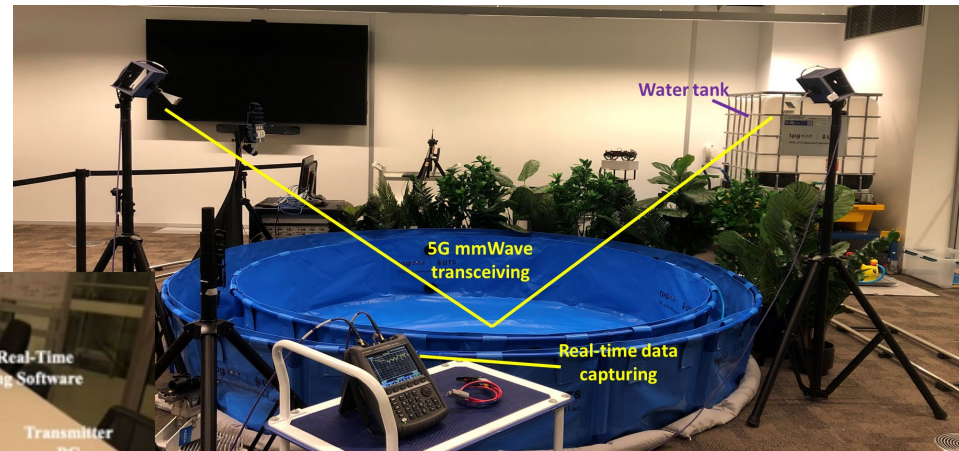
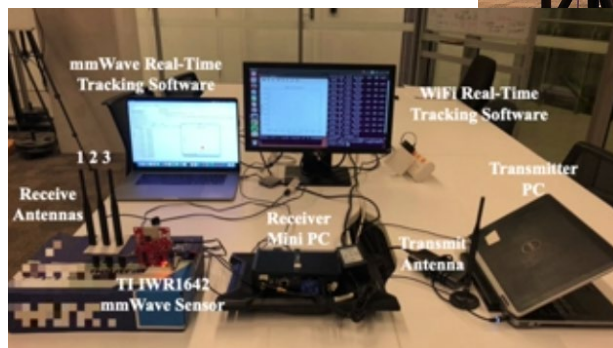

Our Lab

Massive MIMO communications platform

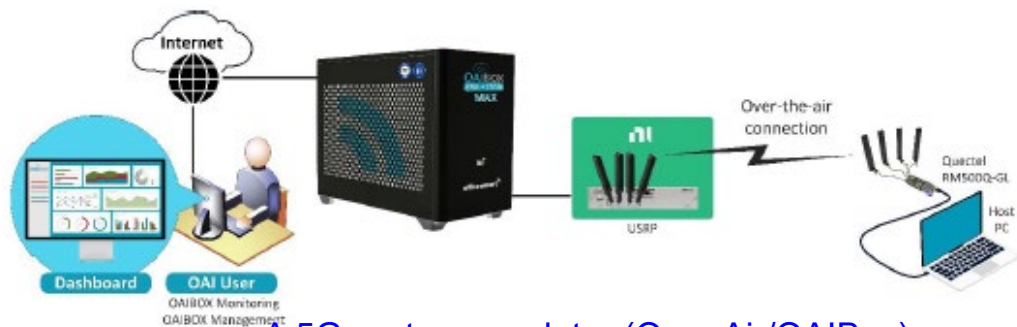

A 5G system emulator (OpenAir/OAIBox)

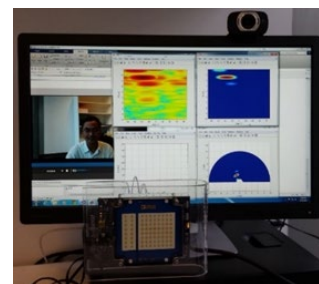

mmWave radar

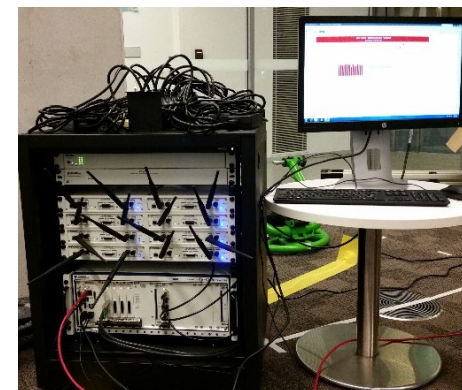

Comparison: Radar, Communications, and ISAC

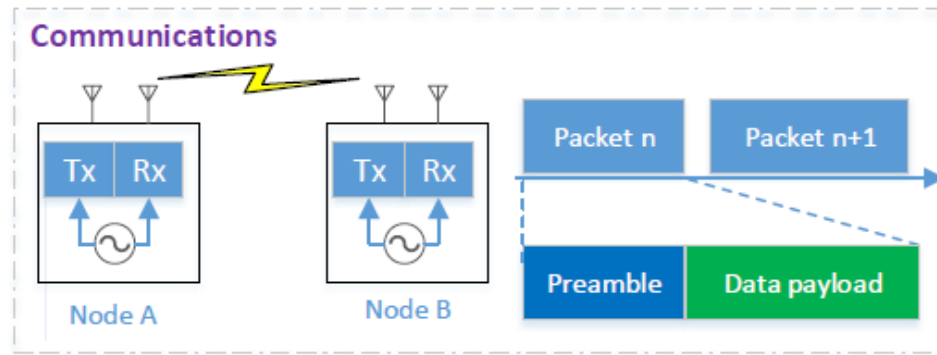
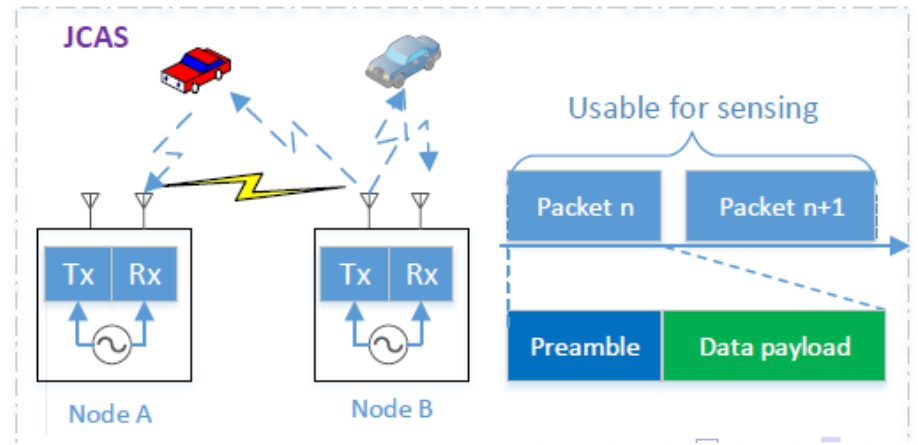
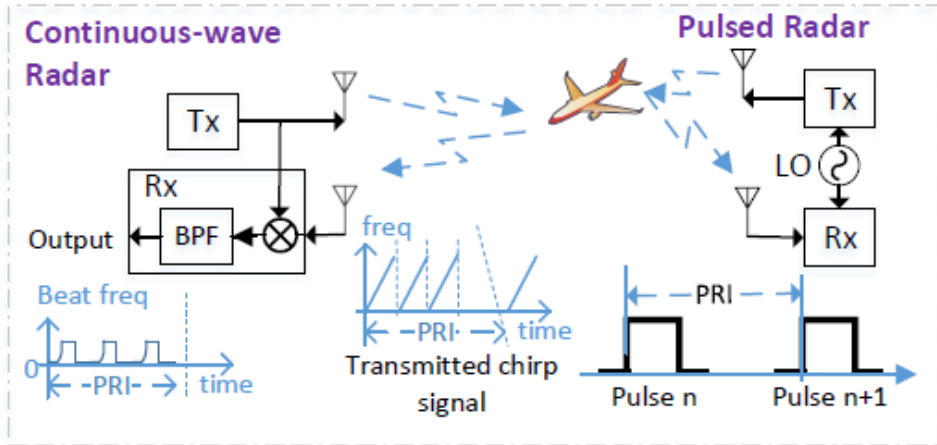

- Mono-static (Full Duplex) vs Bi-static (Clock asynchrony)
- Signal waveform
- Bandwidth
- Transmission power

How to do Sensing in PMN?

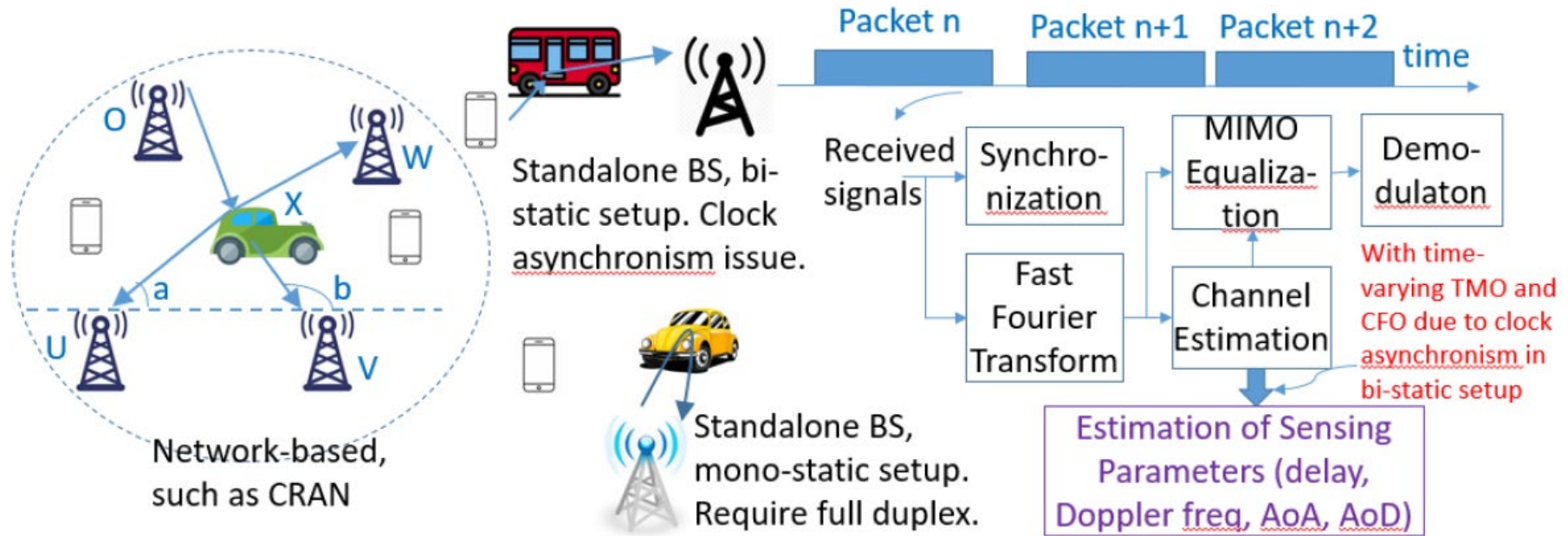

- Multiple signals can be used for sensing
- Uplink sensing at BS can be realized without changing network infrastructure.
- Purely software implementation on edged computing device is possible.

Sensing Parameter Estimation (No Clock Asynchronism)

For CSI-based sensing, the (m_R, m_T) -th element in $\tilde{\mathbf{H}}_{n,k}$:

$$\begin{aligned} & \tilde{h}_{n,k,m_R,m_T} \\ &= \sum_{\ell=1}^L b_{\ell} e^{-j2\pi n\tau_{\ell}f_0} e^{j2\pi k f_{D,\ell} T_s} \\ & \quad \cdot e^{j2\pi d_R m_R \sin(\phi_{\ell})/\lambda} e^{j2\pi d_T m_T \sin(\theta_{\ell})/\lambda}, \end{aligned}$$

Known as a 4-D *Harmonic retrieval* problem.

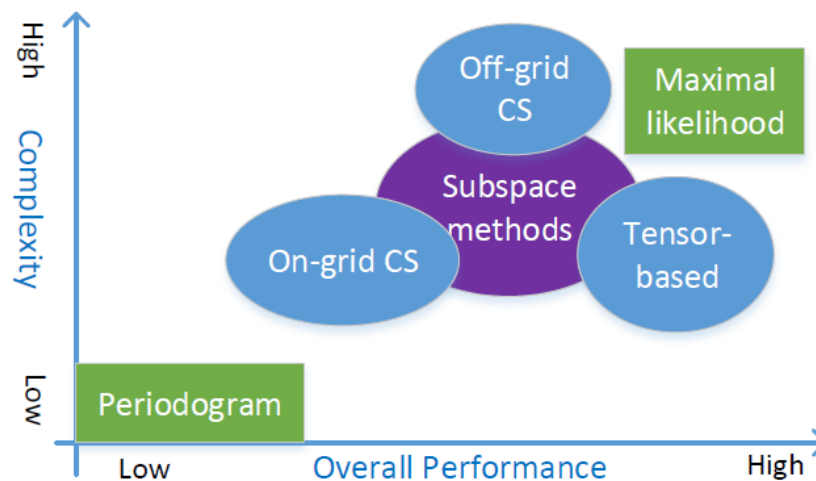

Challenge – Deal with non-continuous measurements due to flexible resource allocation in comm systems.

Zhang et al., “Enabling Joint Communication and Radar Sensing in Mobile Networks -A Survey”, IEEE CS&T, 2021

Bistatic Sensing with Clock/LO Asynchronism – The problem

$$\tilde{\mathbf{H}}_n(t) = e^{j\beta t} \sum_{l=1}^L b_l e^{-j2\pi n(\tau_l + \tau_o(t))f_0} e^{j2\pi(f_{D,l} + f_o(t))t} \cdot \mathbf{a}(M_R, \phi_l) \mathbf{a}^T(M_T, \theta_l).$$

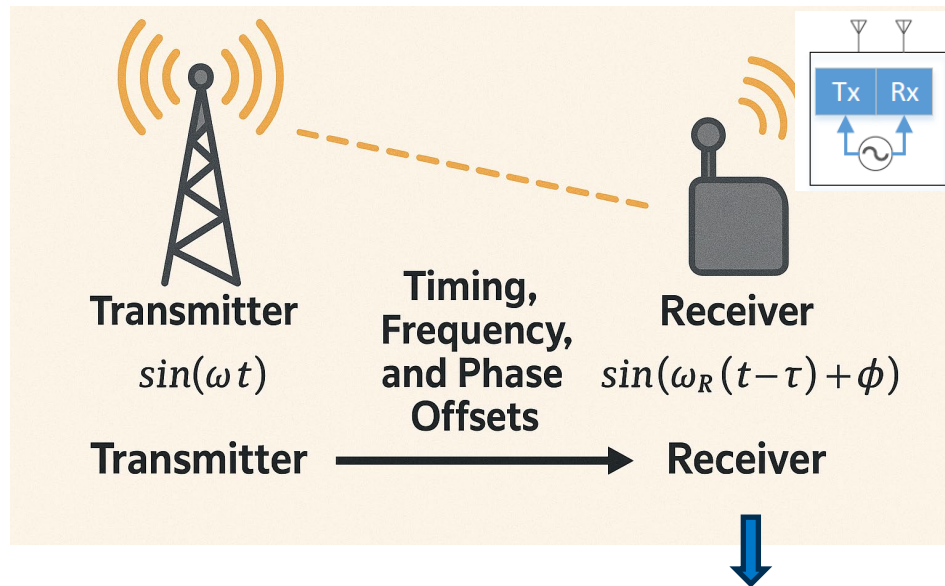

Ambiguity in ranging and speed estimation;
Non-coherent parameter estimation across snapshots.

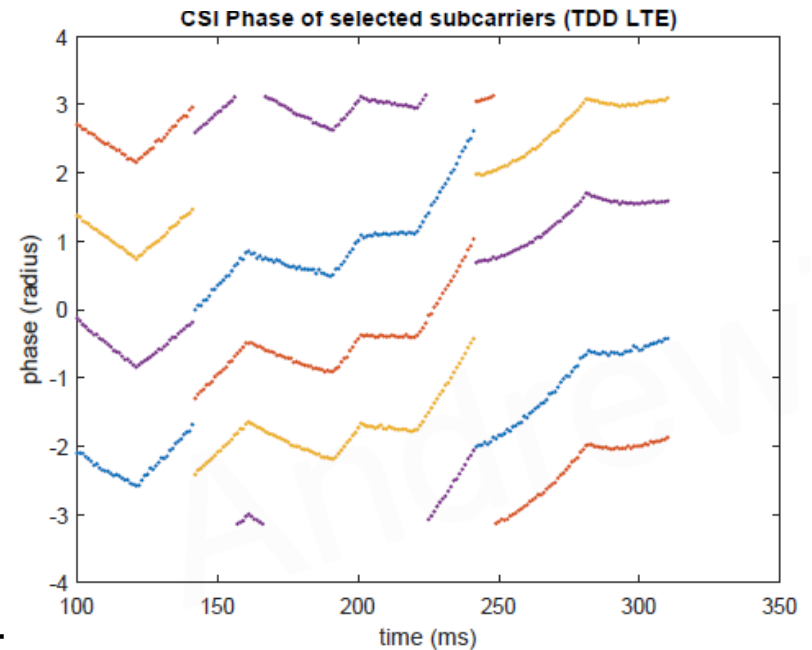

Conventional Techniques in Passive Radar

- Use a dedicated Rx with a directional antenna (array) to create a LOS path between the Tx and Rx.
- Inconvenient to realize; LOS path may not always be available.

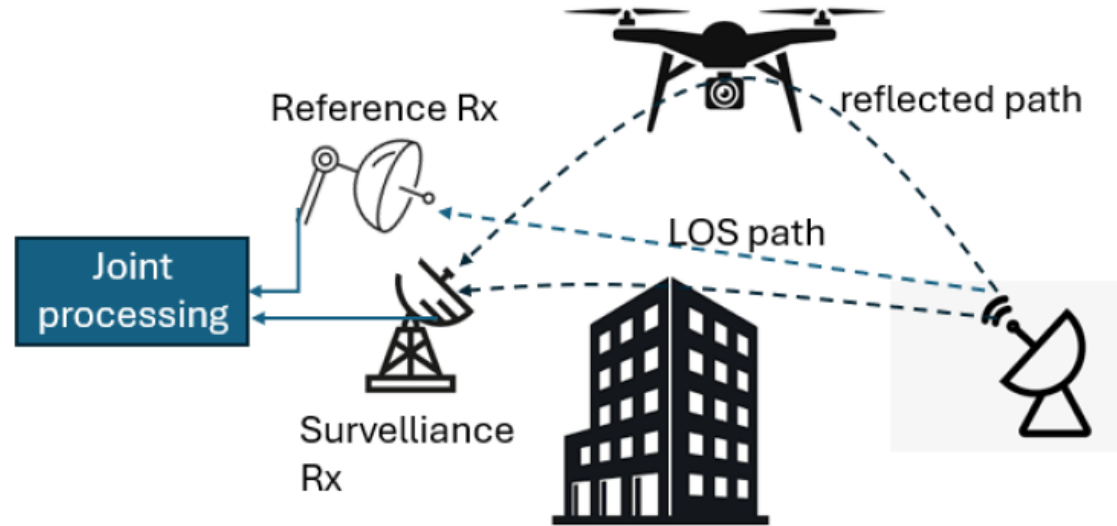

Bistatic Sensing Techniques – An Overview

$$\tilde{\mathbf{H}}_n(t) = e^{j\beta t} \sum_{\ell=1}^L b_{\ell} e^{-j2\pi n(\tau_{\ell} + \tau_o(t))f_0} e^{j2\pi(f_{D,\ell} + f_o(t))t}.$$

$$\mathbf{a}(M_R, \phi_{\ell}) \mathbf{a}^T(M_T, \theta_{\ell}),$$

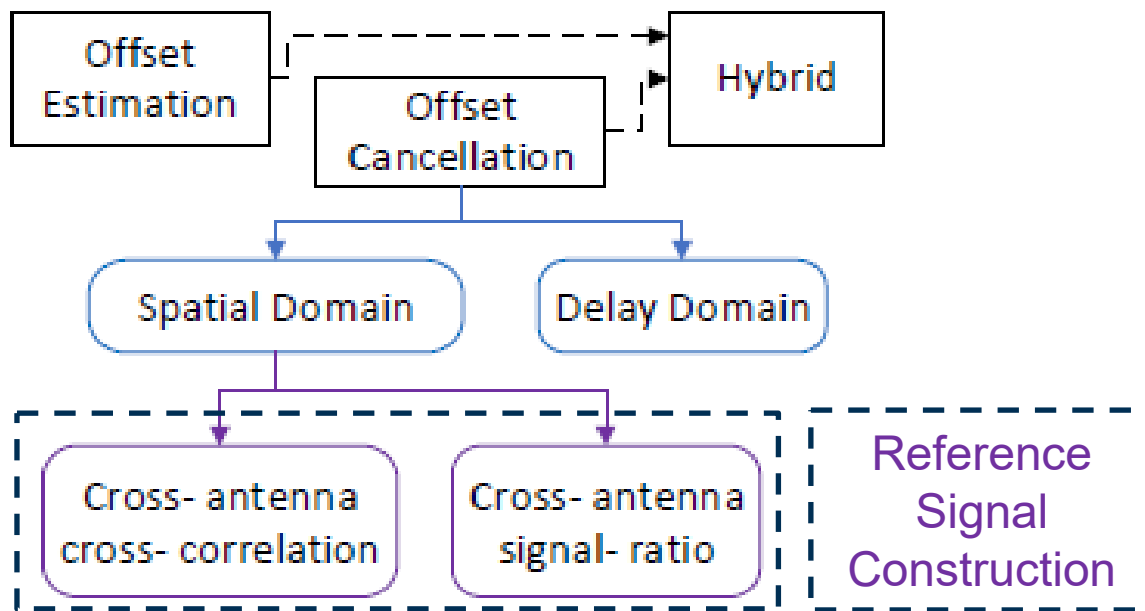

- Critical single-node based techniques for bi-static sensing;
- Application dependent: Doppler only + localization
- Offset cancellation, estimation, and hybrid
- Cross-correlation, CSI ratio
- Reference signal options: raw CSI vs constructed
- Applicable to signals across space/freq/time domains.

"Sensing in Bi-Static ISAC Systems with Clock Asynchronism: A Signal Processing Perspective", IEEE SPM, 2024

Cancellation: Cross Antenna Cross Correlation (CACC)

$$R(n, k, m) = \sum_{\ell_m=1}^L \sum_{\ell_{m_0}=1}^L b_{\ell_m} b_{\ell_{m_0}}^* e^{-j2\pi n(\tau_{\ell_m} - \tau_{\ell_{m_0}})f_0} e^{j2\pi k(f_{D,\ell_m} - f_{D,\ell_{m_0}})T_s} e^{jm\pi(\sin(\phi_{\ell_m}) - \sin(\phi_{\ell_{m_0}}))} |\tilde{X}_{n,k}|^2.$$

New problems we face:

- Parameters become relative;
- More output terms, and some of them are image terms;
- Images cause sensing ambiguity.

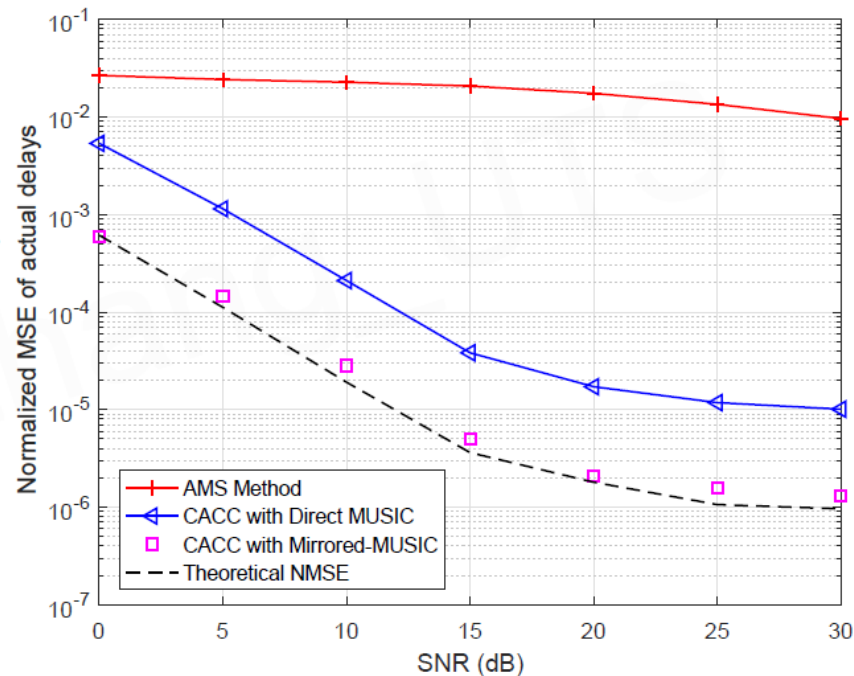

Mirrored MUSIC [1]

1. "Uplink Sensing in Perceptive Mobile Networks with Asynchronous Transceivers", IEEE TSP 2021

Cancellation: Cross Antenna Signal Ratio (CASR, aka, CSI Ratio)

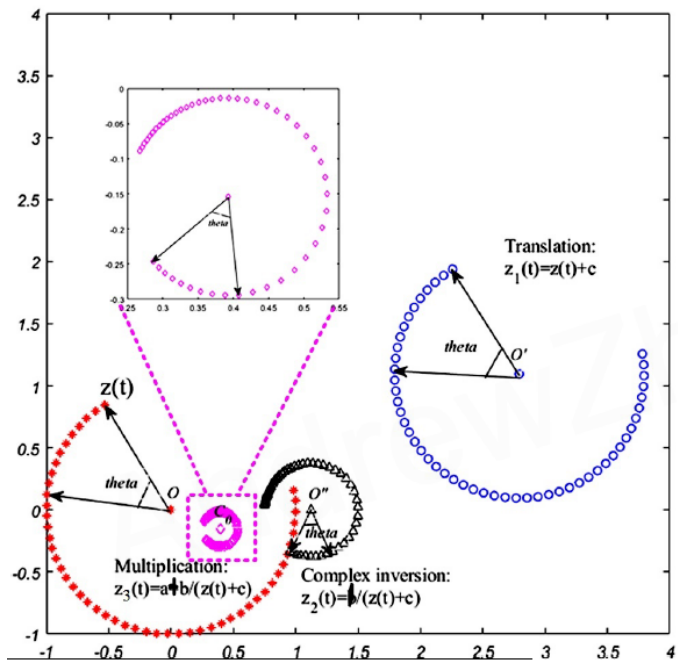

Exploit CSI ratio for Doppler estimation [1]

- Estimate the center of the arc
- Estimate the period of CSI ratio phase

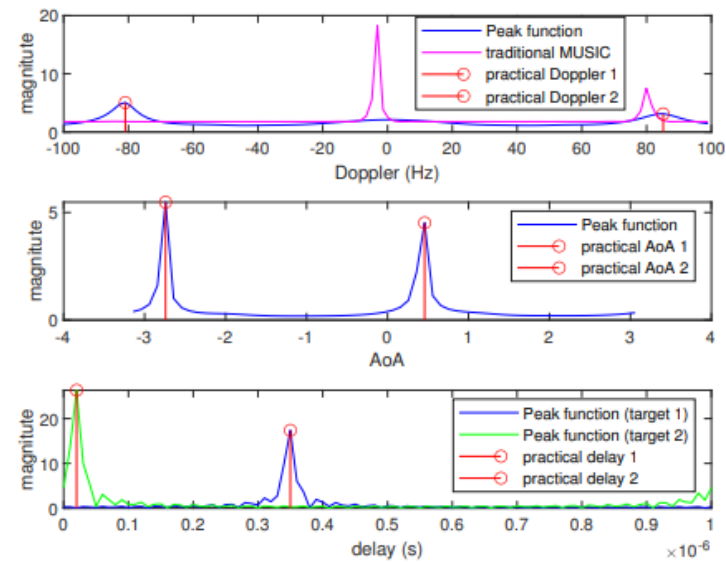

Use Taylor series to represent CSI ratio to resolve non-linear problem [2]

1. "CSI-Ratio-Based Doppler Frequency Estimation in Integrated Sensing and Communications," IEEE Sensors Journal, 2022
2. "Uplink Sensing Using CSI Ratio in Perceptive Mobile Networks", IEEE TSP 2023

$$r(m, n, t) \quad \text{Mobius transform}$$

$$= e^{ju_d} + \frac{\frac{1}{b_d} (H_s(m+1, n) - H_s(m, n)e^{ju_d})}{\frac{1}{b_d} H_s(m, n) + e^{-j2\pi(n\tau_d f_0 - f_D t)}}$$

Cross-Frequency Sensing (Single Antenna)

Cross-frequency cross correlation (CFCC) and cross-frequency signal ratio (CFSR) techniques

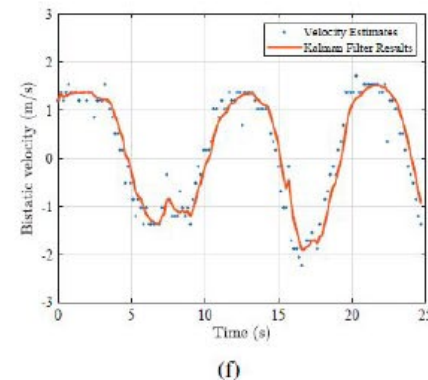
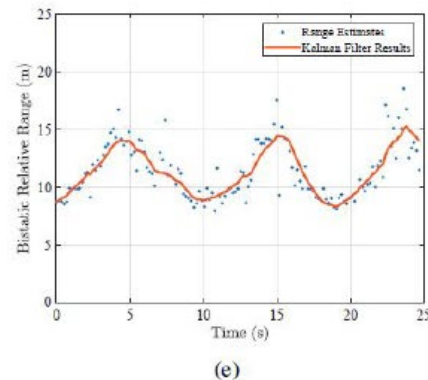
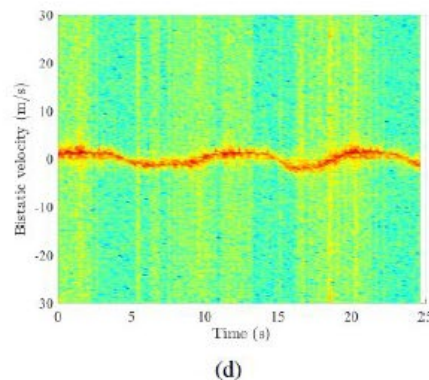
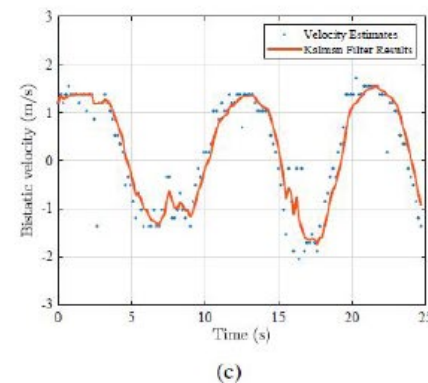
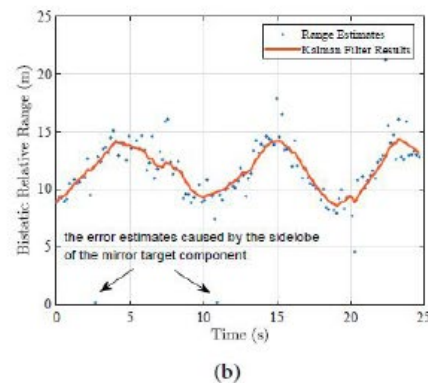
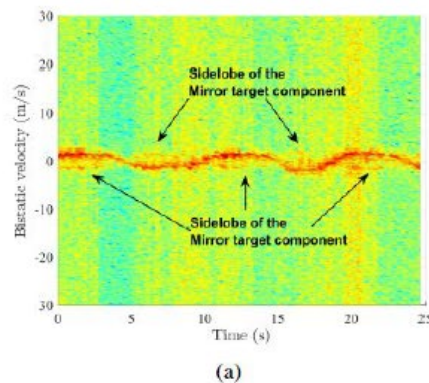

Yanmo Hu et al., "Cross-Frequency Sensing in Bistatic ISAC Systems". IEEE TWC (2025)

Construction of Reference Signals -1: Overview

$$\begin{aligned} & \tilde{y}_{n,k,m} \\ &= e^{j\beta_k} \sum_{\ell=1}^L b_{\ell} e^{-j2\pi n(\tau_{\ell} + \tau_{o,k})f_0} \\ & \quad e^{j2\pi k(f_{D,\ell} + f_{o,k})T_s} e^{jm\pi \sin(\phi_{\ell})} \tilde{x}_{n,k}. \end{aligned}$$

$$x_{\text{ref}} = f(e^{j\beta_k}, e^{-j2\pi n\tau_{o,k}f_0}, e^{j2\pi kf_{o,k}}) \tilde{x}_{n,k}$$

Ideally

$$\begin{aligned} &= e^{j\beta_k} b_1 e^{-j2\pi n(\tau_1 + \tau_{o,k})f_0} \\ & \quad e^{j2\pi kf_{o,k}T_s} e^{jm\pi \sin(\phi_1)} \tilde{x}_{n,k}. \end{aligned}$$

- CACC and CASR implicitly use full CSI as reference signals.
- Construct one with reduced number of paths to reduce interference in CC and SR methods - containing same offsets.
- Good for channels with a dominating path.
- Either multiplication or division with Reference Signal.
- Possible for using data payload for sensing by removing unknown data symbols.

Construction of Reference Signals 2: Domain and Path Selection

- Domains (time, space, freq) and Construction methods (Coarse vs fine)
- Examples
 - Peak of td-CSI (Simple, low resolution);
 - Use compressive sensing to construct td- path;
 - BF enhancement and null space suppression.

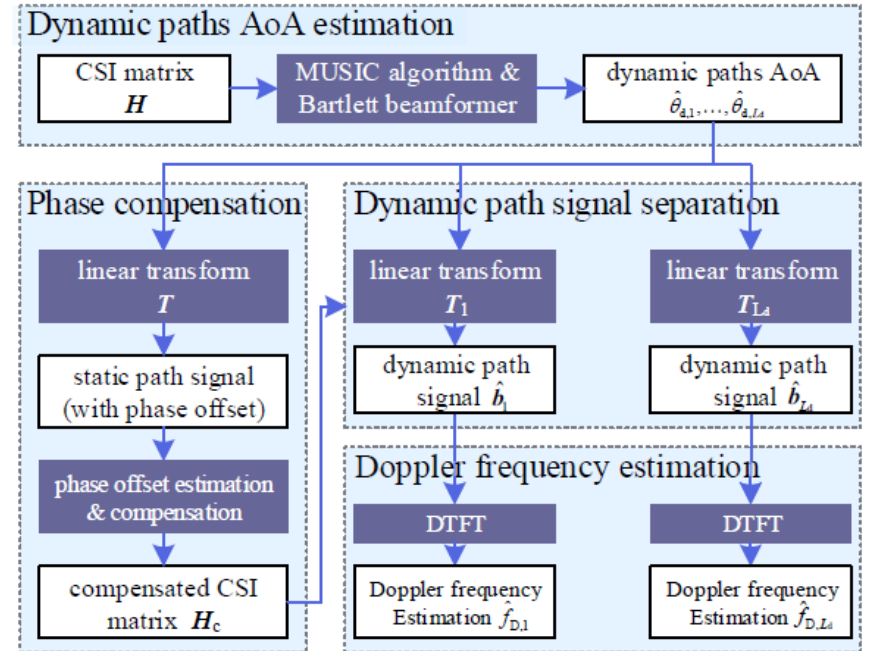
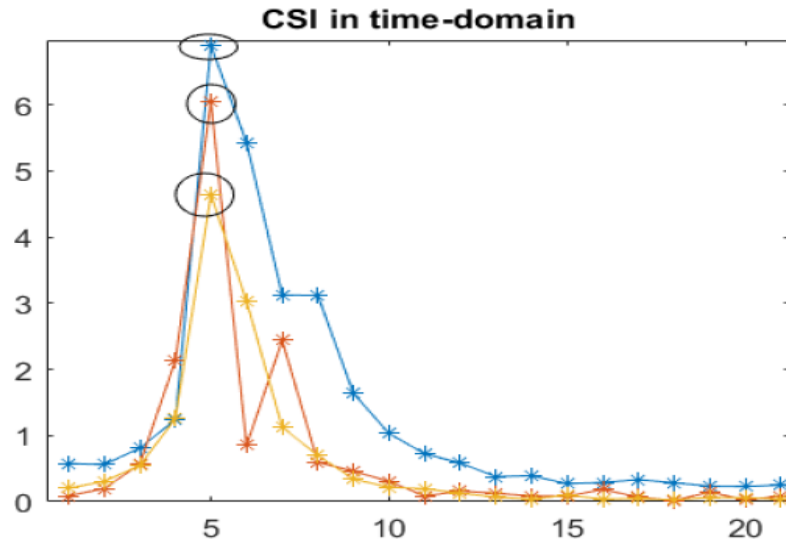

Kai Wu et al. "A Low-complexity CSI-Based Wi Sensing Scheme for LoS-Dominant Scenarios". IEEE ICC 2023.
 Jingbo Zhao et al. "Multiple-Target Doppler Frequency Estimation in ISAC with Clock Asynchronism". IEEE TVT, 2023

Subspace-based Reference Construction

- Signal subspace represents more reliable reference signals – aggregation of signals, instead of a single path

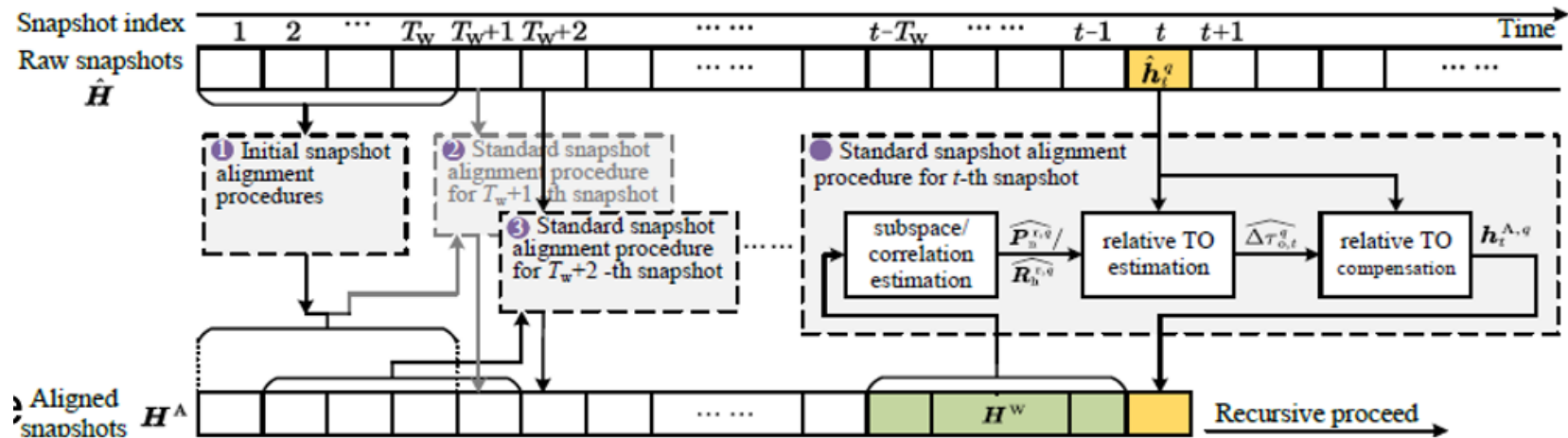

Jingbo Zhao et al. "Subspace-Based Super-Resolution Sensing for Bi-Static ISAC with Clock Asynchronism". *IEEE JSAC*, 2025

Generalisation and Future Research Directions

- Relax the assumptions:
Dominating LOS path;
Known Tx location
- Extend to more complicated scenarios: multiple dynamic objects, mobile platform
- Generalization to more domains;
- Subspace based reference signals
- Networked sensing (Multi-Tx and Rx)

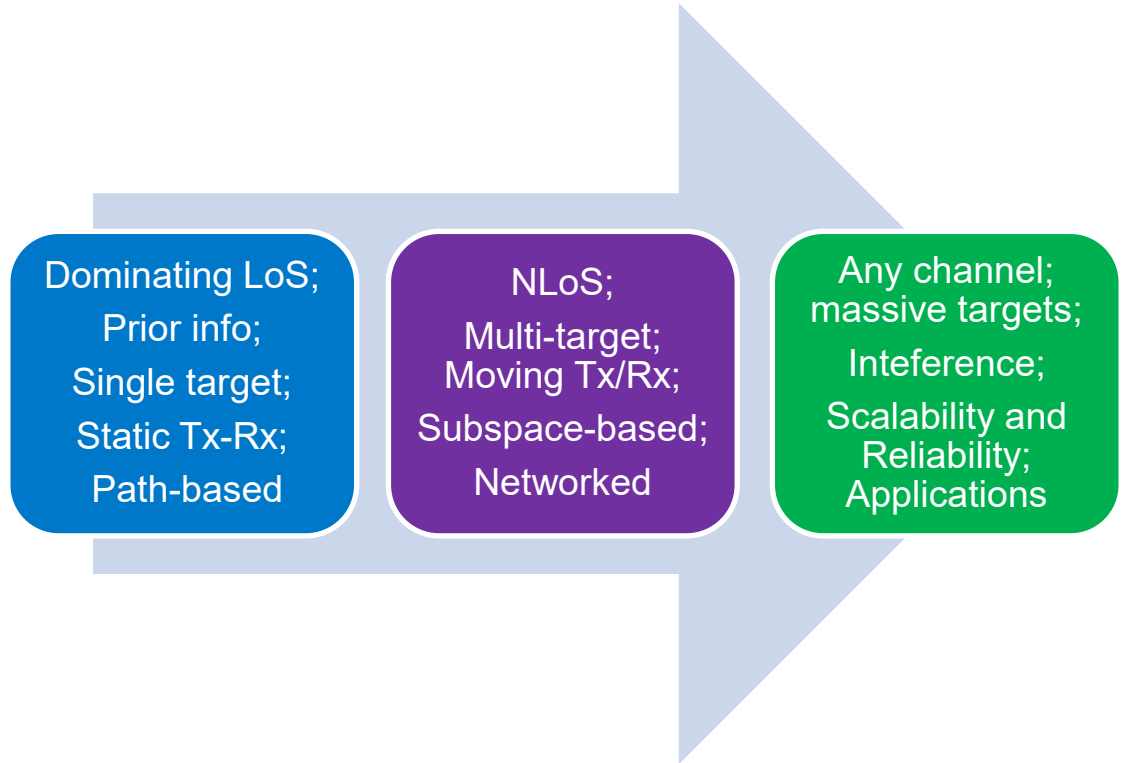

Networked Sensing: Shifting from Multi-Rx to Multi-Tx

Limitations of current mainstream setup: Multi-Rx/BS sensing (Typically leverage C-RAN. Distributed-antenna architecture)

- Dense BSs with accurate clock synchronisation
- High data-rate connection between BSs
- Limited multi-view and coverage

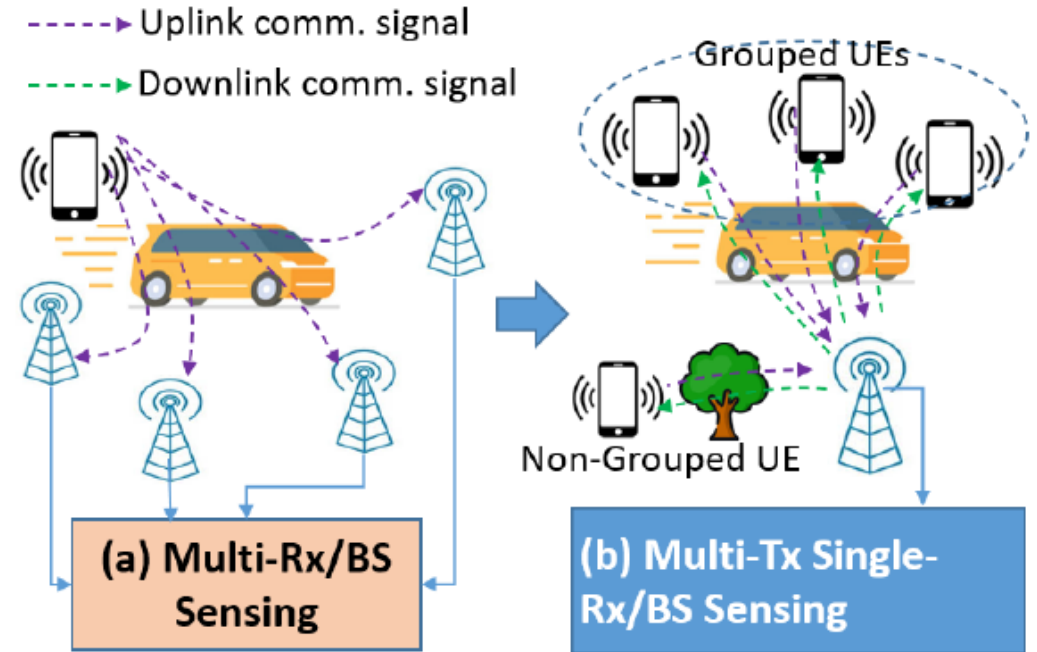

Multi-Tx Networked Sensing has great Potential

- Basic ideas: UEs at proximity have correlated channels; Group UEs for distributed sensing at BS; Uplink and/or combined downlink (Relay).
- Advantages: Multi-view and spatial diversity; Align perfectly with Multiuser access network.
- Challenges
 - Sensing algorithms that can capture the correlation
 - UE grouping and localization (single BS?)
 - Sensing with moving nodes
 - Resource allocation/optimization

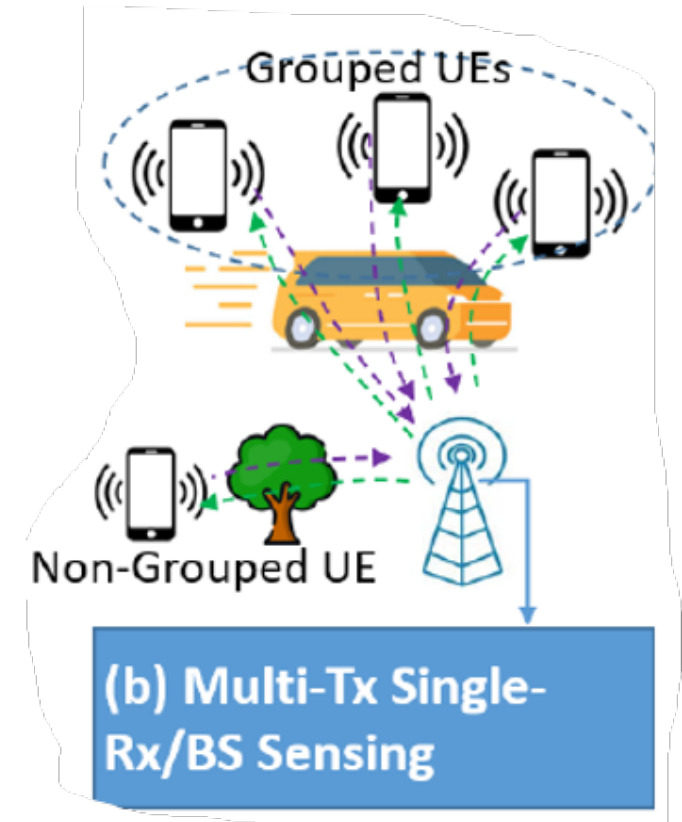

Uplink Networked Sensing via Multiuser Correlation Exploitation (OFDMA)

1. Sparsity model capturing delay correlation
 - Multiple-measurement-vector (MMV) model with clustered channels
 - Shared-private decomposition
2. Remove TO using LoS path delay reference
3. Perform delay-clustering SBL to recover the active delay support
4. Remove CFO/PO from estimated support coefficients
5. Estimate Doppler and angles

$$\mathbf{Y}_k[t] = \mathbf{\Psi}_{\tau,k} \bar{\mathbf{W}}_k[t] + \mathbf{E}_k[t],$$

$$\mathbf{W}_k[t] = \mathbf{W}_k^{\text{sh}}[t] + \mathbf{W}_k^{\text{pr}}[t],$$



$$\bar{\mathbf{Y}}_k[t] \approx \mathbf{B}_k \hat{\mathbf{X}}_k[t] + \mathbf{E}_k[t],$$

$$\hat{\mathbf{X}}_k[t] = (\mathbf{B}_k^H \mathbf{B}_k + \lambda \mathbf{I})^{-1} \mathbf{B}_k^H \bar{\mathbf{Y}}_k[t],$$

J. Bao, J. A. Zhang, et al, "Uplink Networked Sensing via Multiuser Correlation Exploitation", arXiv:2603.16442, 03/2026

Simulation Results

MULTI-USER CLUSTERING ACCURACY VERSUS SNR.

SNR (dB)	-5	0	5	10	15
Clustering accuracy	0.502	0.689	0.812	0.868	0.899

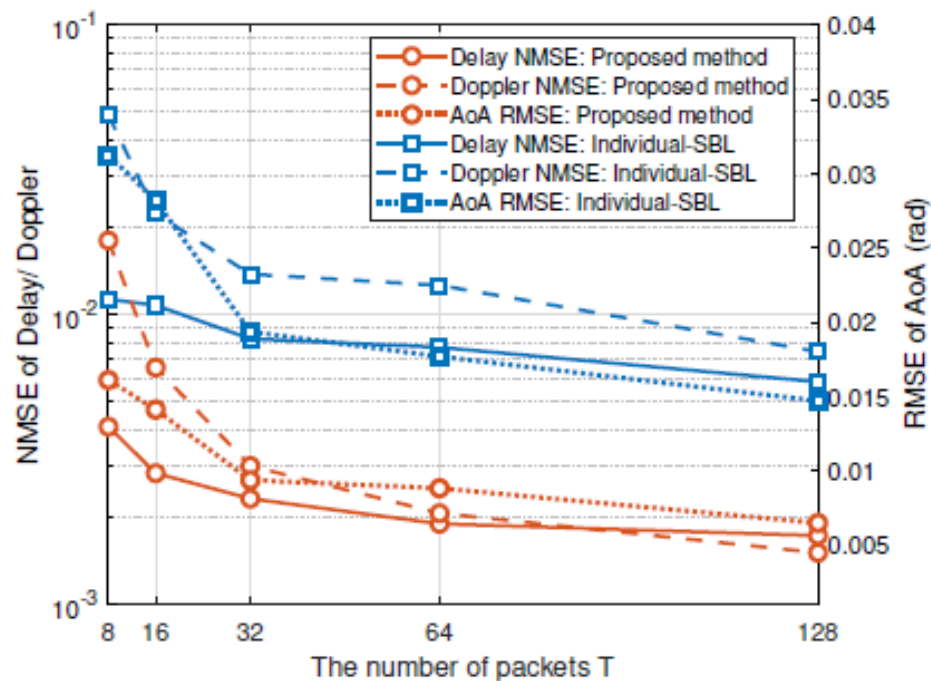
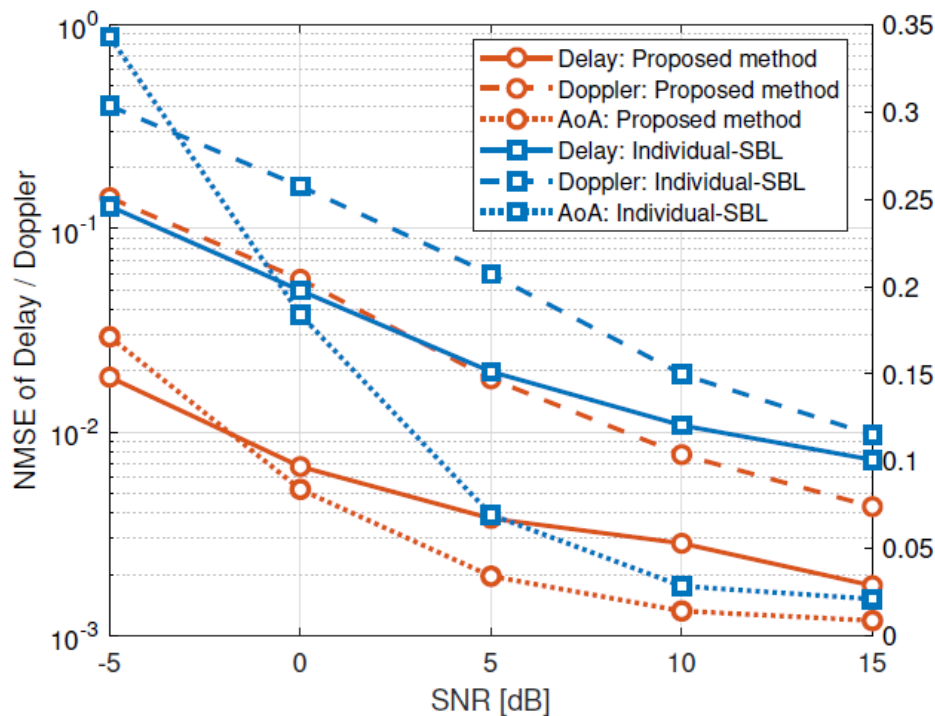

Exemplified Project 1:

Network as an Environmental Sensor: Water and Rainfall Sensing

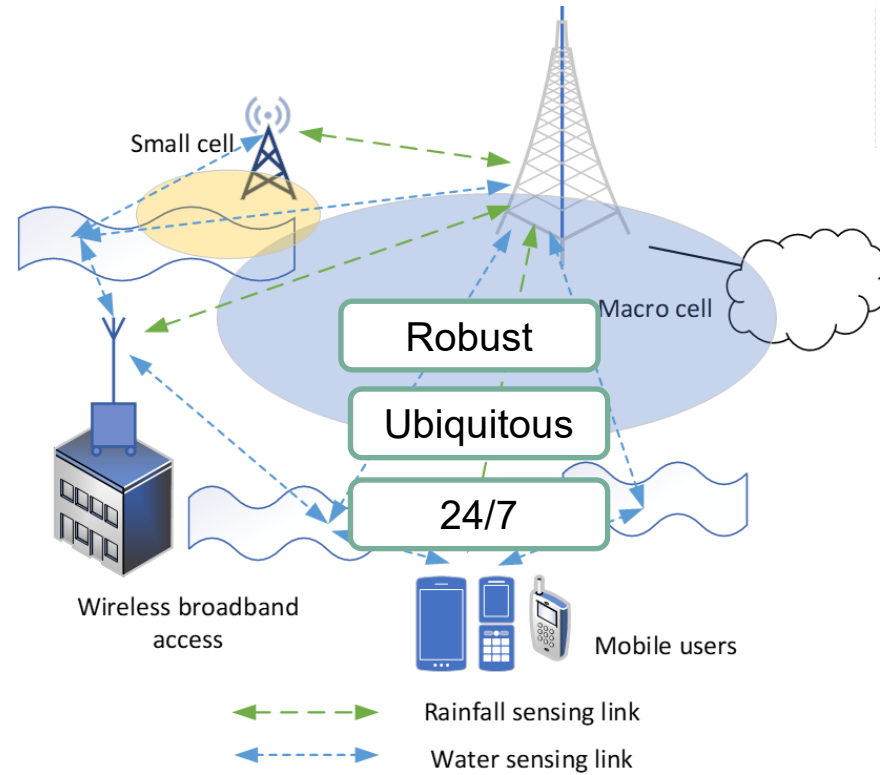

Environmental Sensing Framework

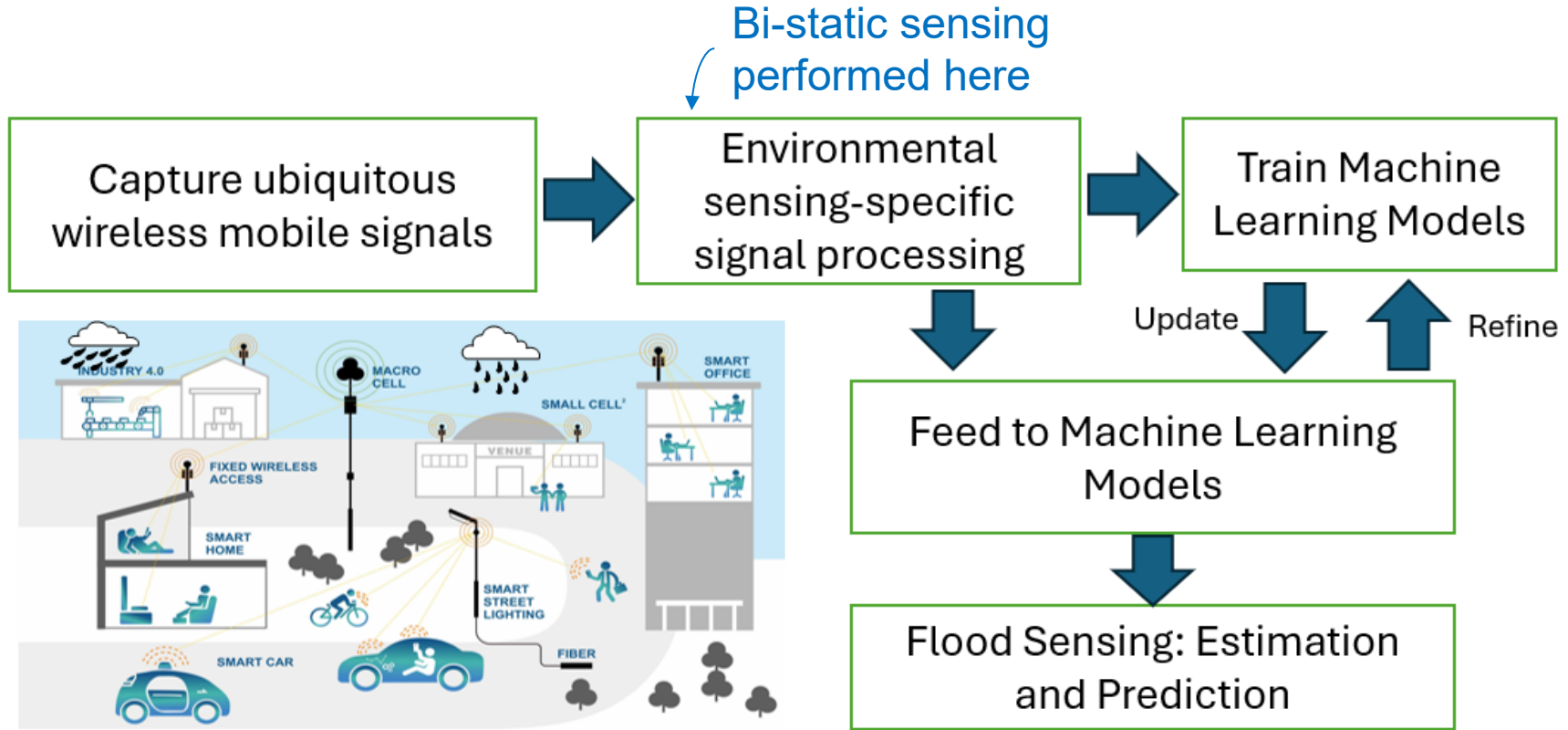

Extensive in-field Data Collection and Experiments

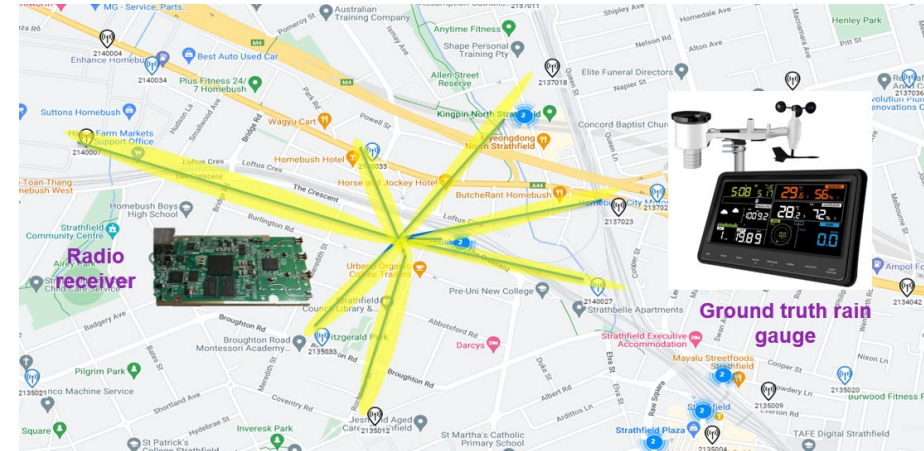
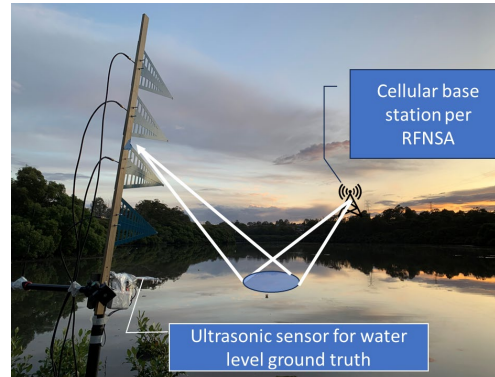

River Water Level Sensing – the Principle

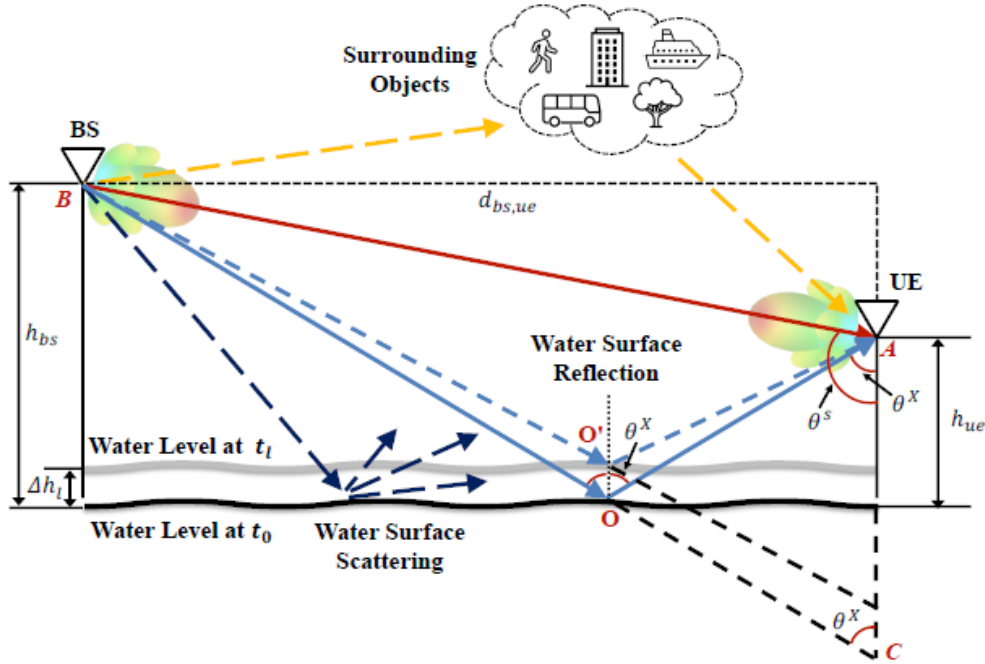

Period of the power of combined signals relate to signal wavelength.

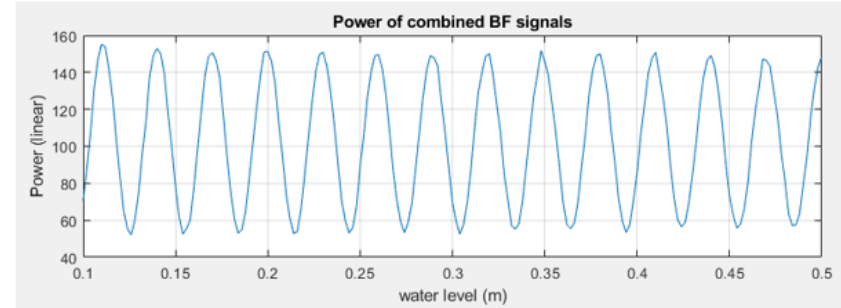

Figure 2 Variation of power of combined signals with water level for millimeter wave signals at 28 GHz (via simulation).

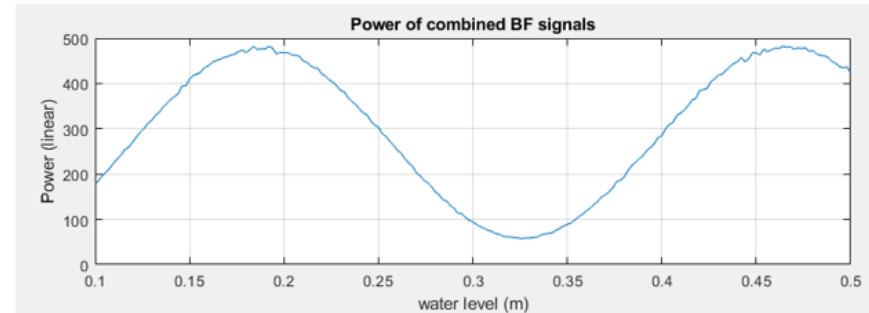

Figure 3 Variation of power of combined signals with water level for signals at 3 GHz (via simulation)

Signal Modelling and Challenges

$$\begin{aligned}
 CSI_{i,j,k} &= \rho_k^{\text{tx}} \rho_k^{\text{agc}} H_i^e H_{j,k}^h (H_{i,j}^S + H_{i,j,k}^X) \\
 &= \underbrace{\gamma_k}_{\text{Power}} \underbrace{e^{-J(\phi_{j,k}^{\text{TO}} + \phi_k^{\text{CFO}})}}_{\text{Phase Offsets}} \underbrace{e^{-J\phi_i^h}}_{\text{Hardware}} \\
 &\quad \left(\underbrace{\sum_{l_1} \rho_{i,j}^S[l_1]}_{\text{Static Components}} \underbrace{e^{-J2\pi f_j \tau_{i_1}^S}}_{\text{Delay}} \underbrace{e^{-J\pi(i-1) \sin \theta^S[l_1]}}_{\text{AoA}} \right. \\
 &\quad \left. + \sum_{l_2} \rho_{i,j,k}^X[l_2] \underbrace{e^{-J2\pi f_j \tau_{i_2}^X}}_{\text{Delay}} \underbrace{e^{-J2\pi f^D[l_2](k-1)\Delta t}}_{\text{Slow-Time Doppler}} \underbrace{e^{-J\pi(i-1) \sin \theta^X[l_2]}}_{\text{AoA}} \right),
 \end{aligned}$$

Representing water level variation speed as a slow-time Doppler parameter

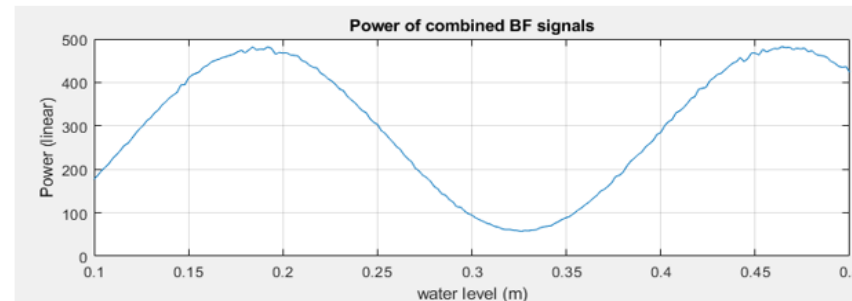

Figure 3 Variation of power of combined signals with water level for signals at 3 GHz (via simulation)

- Information extraction in the presence of hardware offsets in bi-static sensing
- Resolution of ambiguity associated with multiple waveform cycles
- Differentiation between water level increasing and decreasing
- Interference suppression

Practical Outdoor Downlink Sensing Experiments



4-antenna LTE receiver.
2.66 GHz, 20 MHz BW.

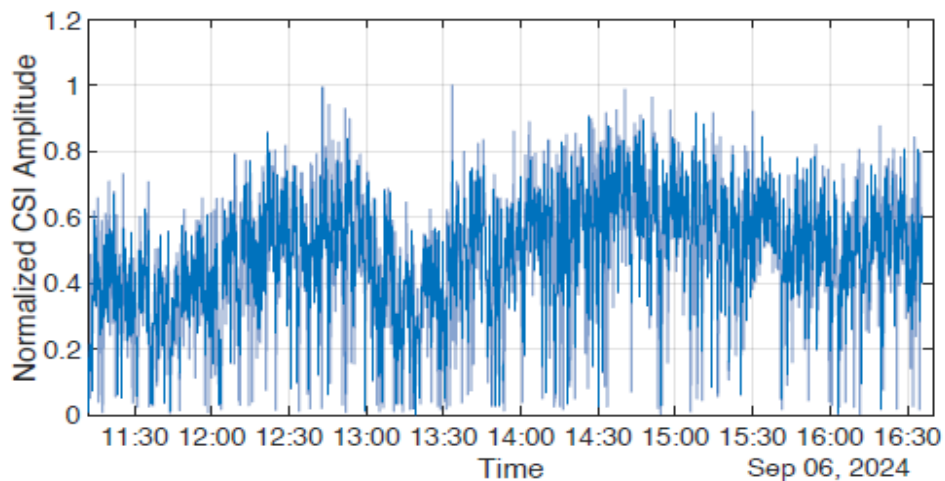

Raw CSI

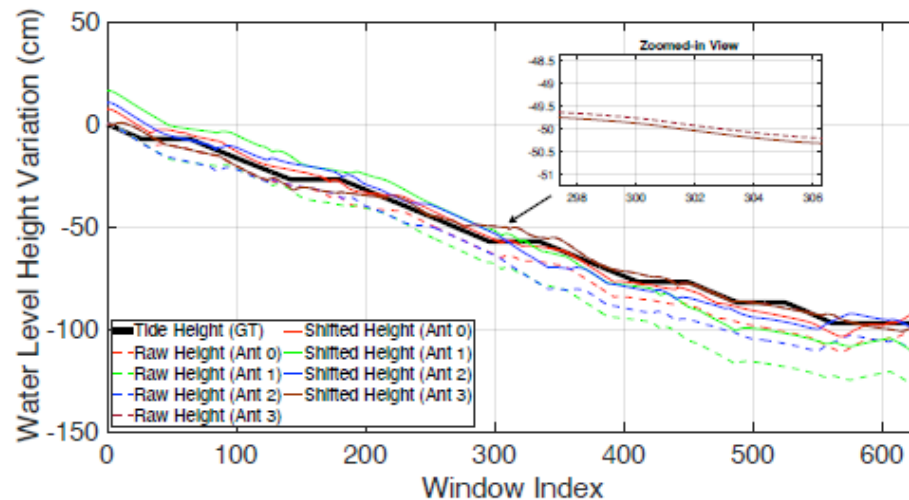

Average error: 4.8 cm, with
a standard deviation of 2.5 cm.

Rainfall Sensing - Underlying Principles

Rain affects microwave propagation via different electromagnetic effects.

Attenuation is the main feature being explored, like in weather radar.

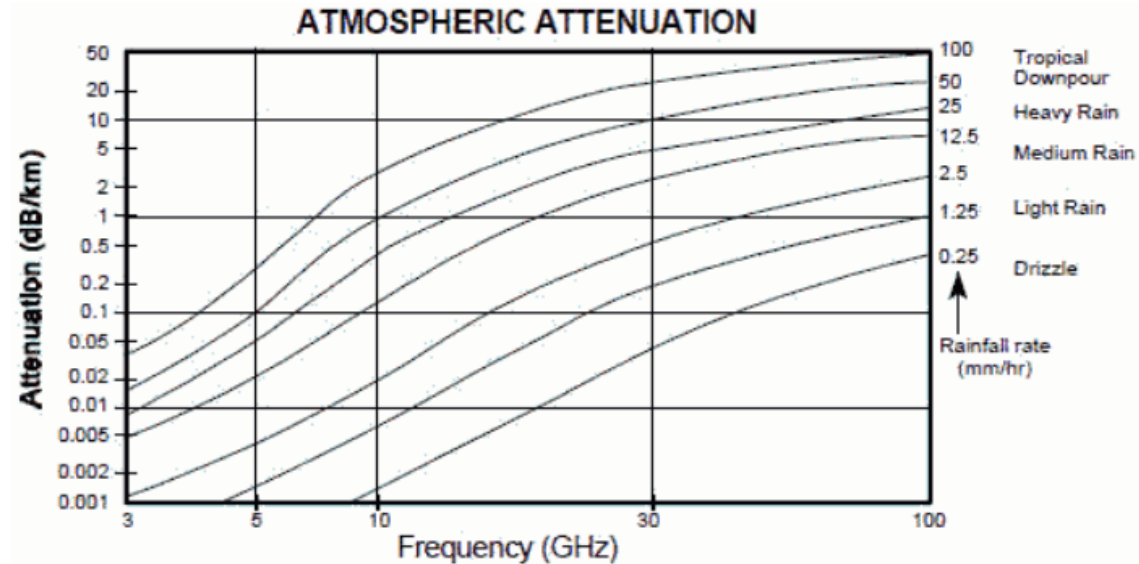
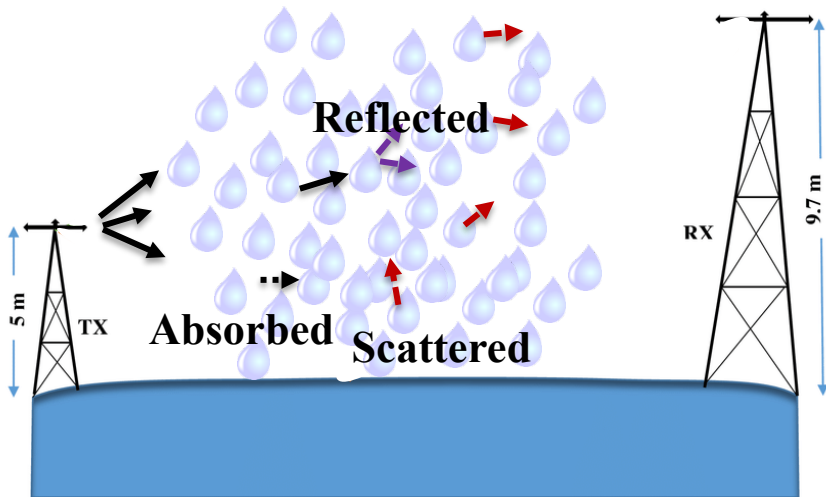

Challenges of Rainfall Sensing Using Mobile Network Signals

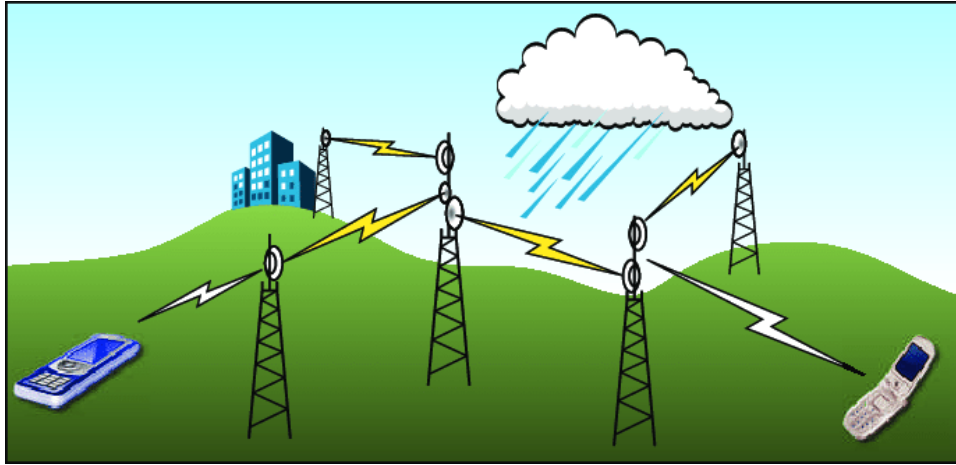

Attenuation-based rainfall sensing using long-range microwave-backhaul connections

Significant challenges in mobile (access) networks, sensing using signals at BS or UE:

- Short distance (~1km)
- Low frequency (900 -4000 MHz)
- UE dynamics
- Associated interference (Wind, distance, angle)
- Independent interference (Vehicle, complicated environment, etc.)
- Power control mechanism

Doppler-based Feature Signal Extraction (Using real downlink mobile communication signals)

Rain intensity shown on Google map

Rain intensity from rain gauges (Ground truth)

Estimated rain intensity from mobile signals

Extracted Doppler feature signals from mobile signals

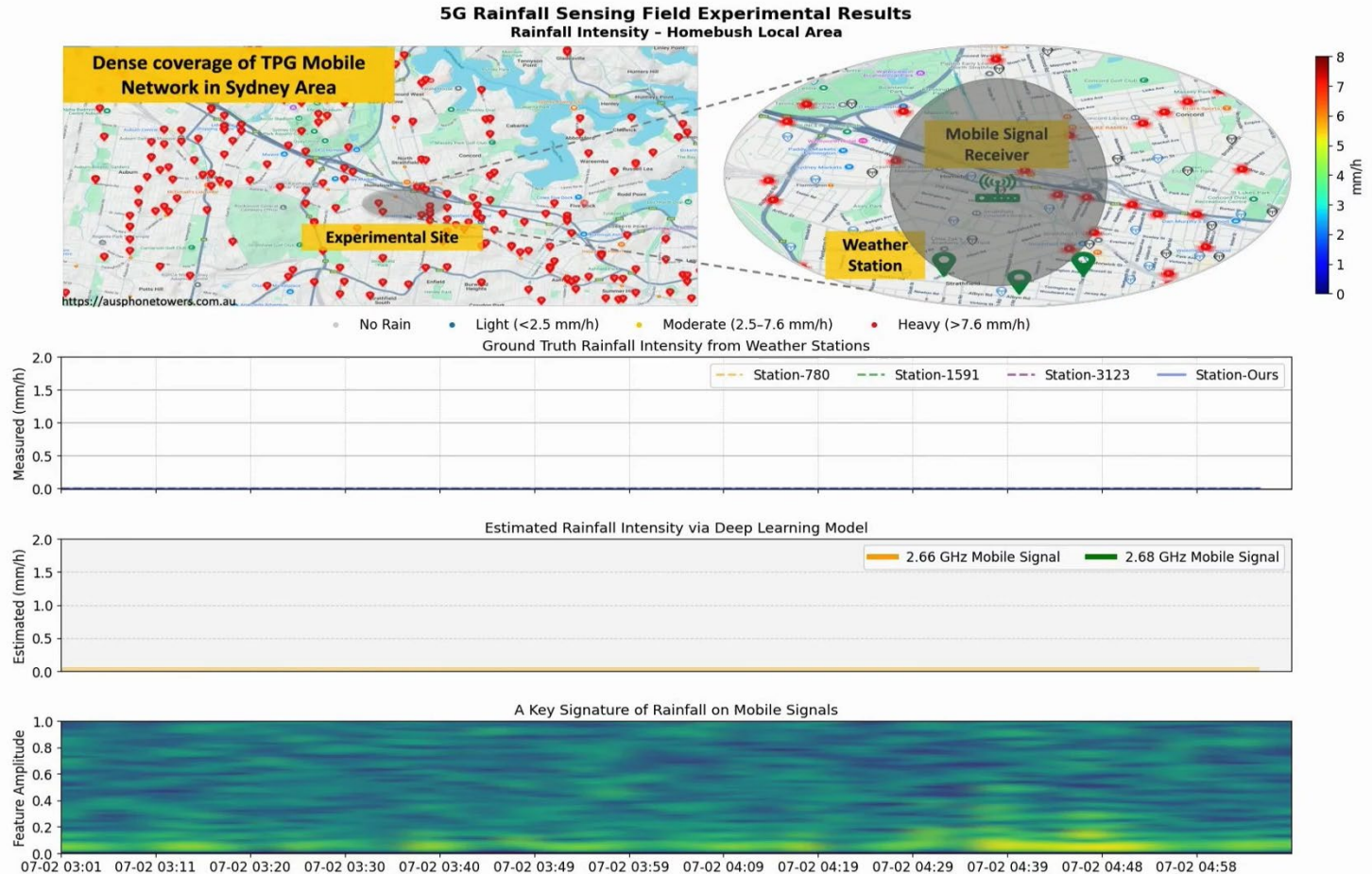

Exemplified Project 2:

WiFi/PMN Sensing for integrated home health, safety and security

- Localization and tracking
- Gesture/Activity recognition
- Biomedical signal extraction (Breathing pattern/heartbeat)
- Presence detection

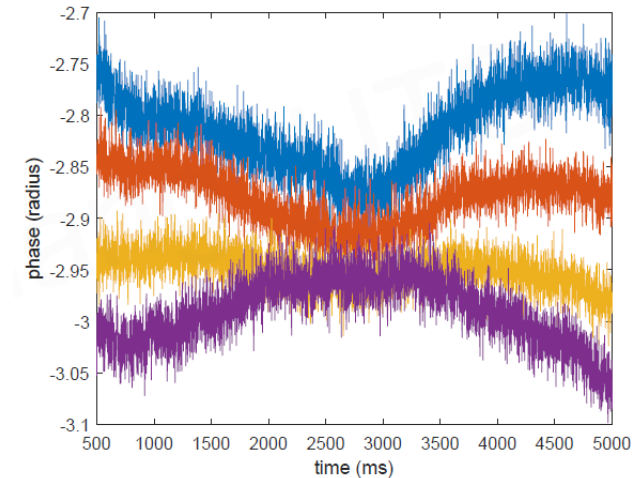
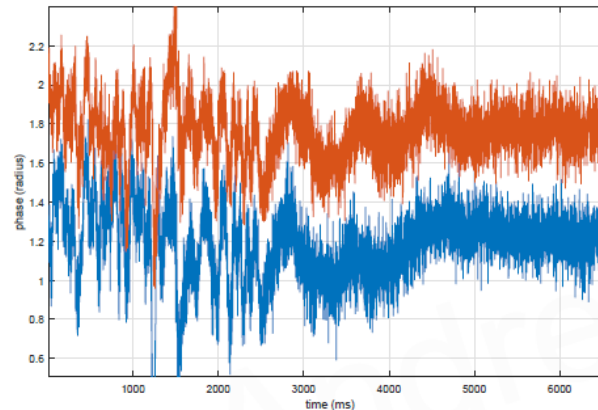
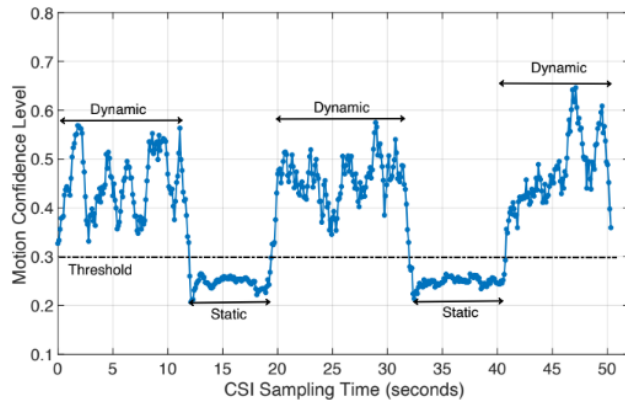

Typical WiFi Sensing Processing Flow

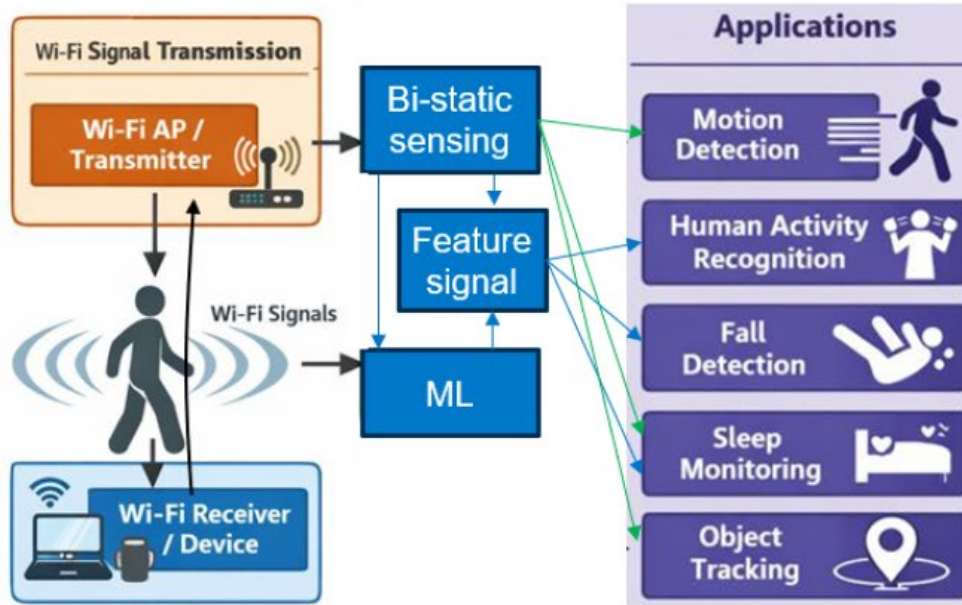

New 802.11bf WiFi Sensing Standard: Define multiple ways for outputting CSI for sensing.

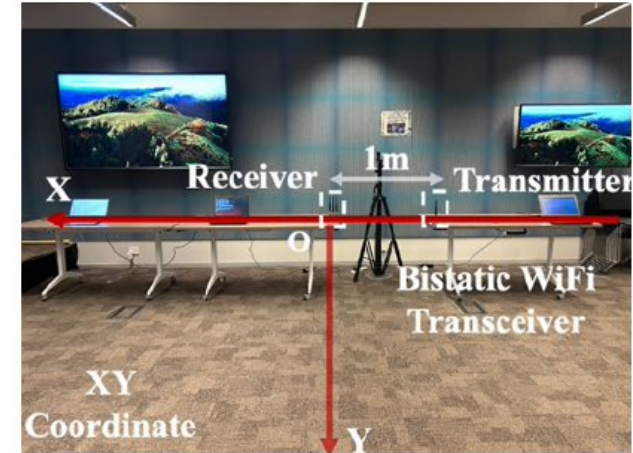

- COTS WiFi NIC @5GHz band, 20/40 MHz bandwidth;
- 1K CSI snapshots/second;
- 1Tx and 3Rx antennas.
- One or two objects.

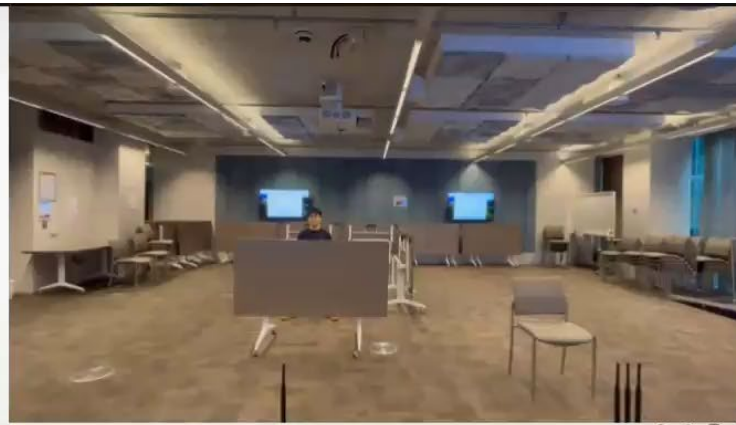

- No calibration required
- Medium tracking error is about 0.5m;
- Single- or multi- Rx antenna
- Extended to multi-target tracking.

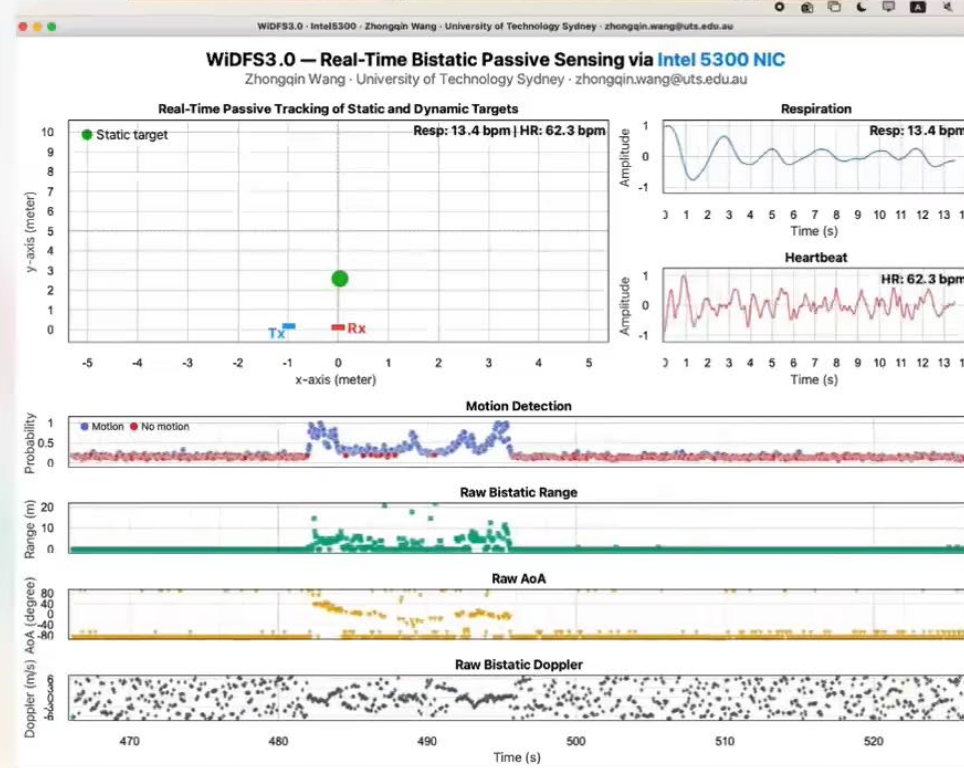

“Passive Human Tracking with WiFi Point Clouds”, IEEE Internet of Things Journal, accepted in Oct 2024.

“Single-Target Real-Time Passive WiFi Tracking”, IEEE TMC 2021

Live Video



WiFi-Based Real-Time Multi-Target Tracking

Real-time Trajectory

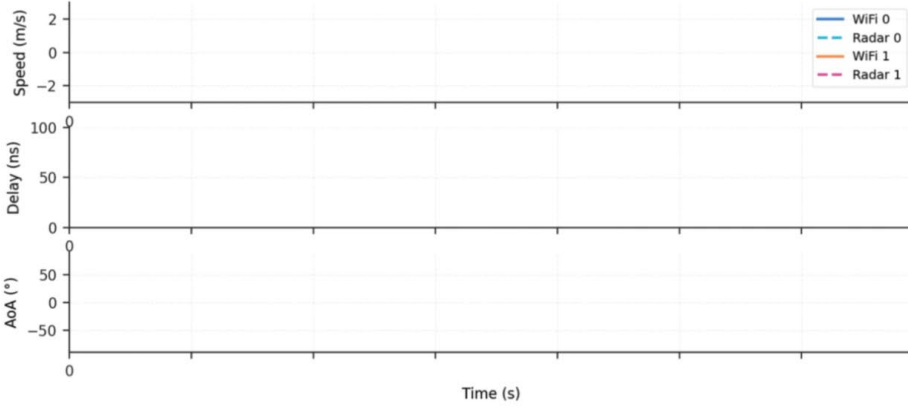
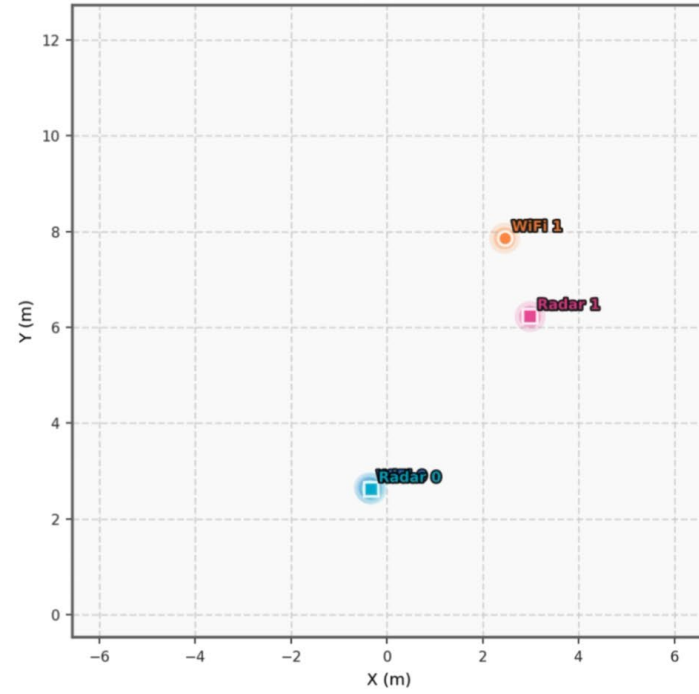

Concluding Remarks

- PMN is expected to deliver a ubiquitous radio sensing network, with negligible influence on communications;
- Bistatic sensing can be realized with little modification to current mobile network infrastructure;
- Great research opportunities in extending bi-static sensing solutions to more general scenarios (particularly multi-Tx networked sensing) and applications.

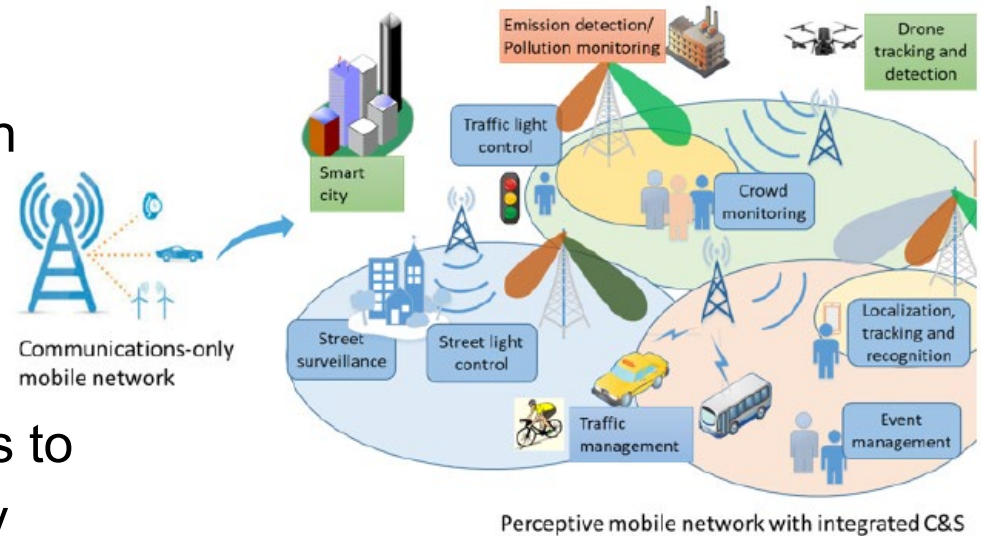

Thank you

Contact: Prof Andrew Zhang

Building 11, Level 8, 81 Broadway, Ultimo NSW Australia

Tel +61 2 9514 7871

Email: Andrew.Zhang@uts.edu.au

Web: <https://www.uts.edu.au/staff/andrew.zhang>

RaSPA Publications:

<https://sites.google.com/view/andrewzhang/publications>



Acknowledgment

- To my UTS collaborators, Prof. Y. Jay Guo, Prof. Xiaojing Huang, Dr. Zhitong Ni, Dr. Kai Wu, Dr. Zhongqin Wang and all contributing students;
- To our external collaborators: Prof. Robert Heath (UCSD), Prof Jinhong Yuan (UNSW), Prof Christos Masouros (UCL), Prof Athina Petropulu, Prof. Zesong Fei (BIT), Dr. Fan Liu (SEU), ..

UTS:
ENGINEERING AND
INFORMATION
TECHNOLOGY