

Signalling, Network-level Design and Security for ISAC

Christos Masouros, Fellow IEEE

Professor of Wireless Communications and Signal Processing

Dept. of Electronic & Electrical Engineering

University College London

c.masouros@ucl.ac.uk



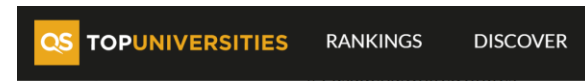

EE

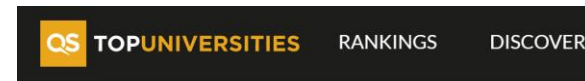
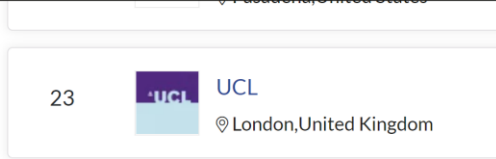

Overall



EEE Research Groups

- Information and Communications Engineering
 - ❖ 9 academic staff,
 - ❖ 2 senior research staff,
 - ❖ 25 research associates
 - ❖ ~50 PhD students,
 - ❖ ~£15M current grants
- Electronic Materials and Devices
- Optical Networks
- Photonics
- Sensors, Systems and Computers

- 🏆 F. Liu, Y. Liu, A. Li, C. Masouros, Y. Eldar, “Cramér-Rao Bound Optimization for Joint Radar-Communication Design”, IEEE Trans. Sig. Proc., vol. 70, pp. 240-253, 2022, doi: 10.1109/TSP.2021.3135692. **The 2024 IEEE SPS Best Paper Award**
- 🏆 F. Liu, C. Masouros, H. Griffiths, A. Petropulu, L. Hanzo “Joint Radar and Communication Design: Applications, State-of-the-art, and the Road Ahead”, IEEE Trans Comms, vol. 68, no. 6, pp. 3834-3862, June 2020, **The 2023 IEEE ComSoc Stephen O. Rice Prize**
- 🏆 F. Liu, L. Zhou, C. Masouros, A. Li, W. Luo, and A. Petropulu “Toward Dual-functional Radar-Communication Systems: Optimal Waveform Design” IEEE Transactions on Signal Processing, August 15, 2018, **The 2021 IEEE SPS Young Author Best Paper Award**
- 🏆 C. Masouros and G. Zheng, “Power Efficient Downlink Beamforming Optimization by Exploiting Interference”, IEEE GlobeCom2015, **best paper award in Signal Processing for Communications (SPC) symposium**





Call: HORIZON-MSCA-2022-DN-01
GA Number: 101120544
Project dates: Jan 2024 – Dec 2027
Value: €2.7m

Integrated Sensing and Communications (ISAC)

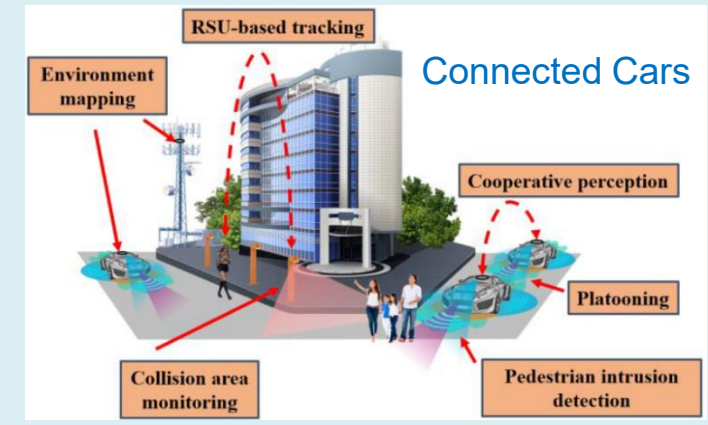
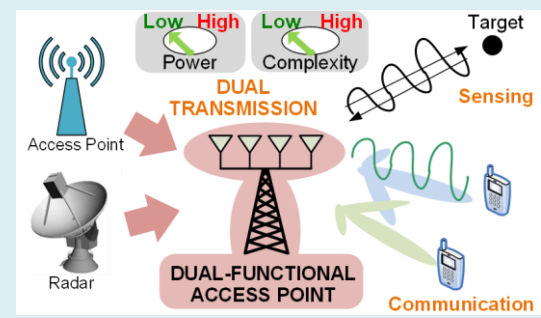

Call: 6G JU-SNS Phase 2
GA Number: 101139176
Project dates: Jan 2024 – Dec 2026
Value: €4.3m

Distributed ISAC

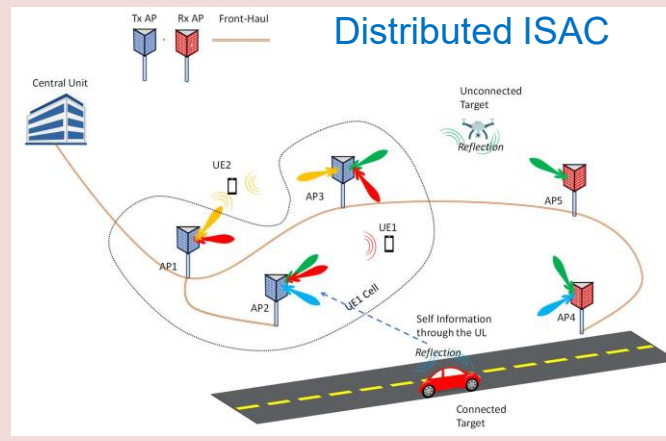

Wireless-Optical Synchronisation

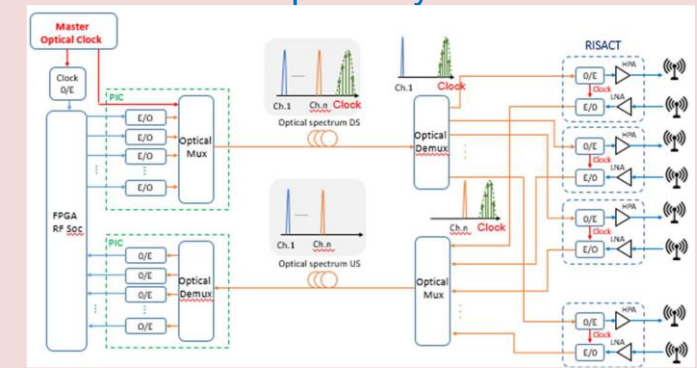

Call: Celtic-Next
GA Number: C2023/2-14
Project dates: Oct 2024 – Sep 2027
Value: €9.3m



Other Projects

- Revol6G:** ISAC through AFDM **Value:** £500k
- ConSent:** non-coherent ISAC **Value:** €230m
- NetISAC:** network-level ISAC **Value:** €230m
- ICON:** ISAC **Value:** £1m

Dual-functional Radar-Communication

Signal Design

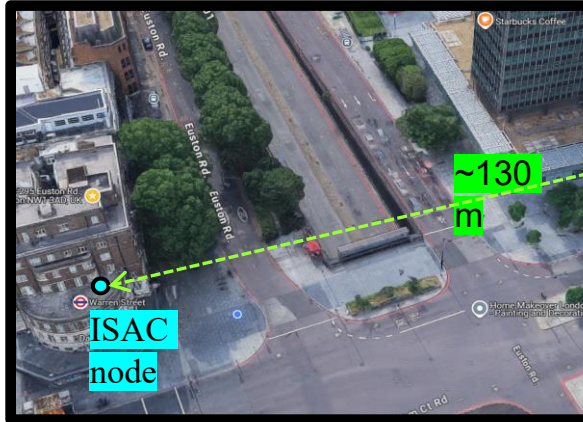
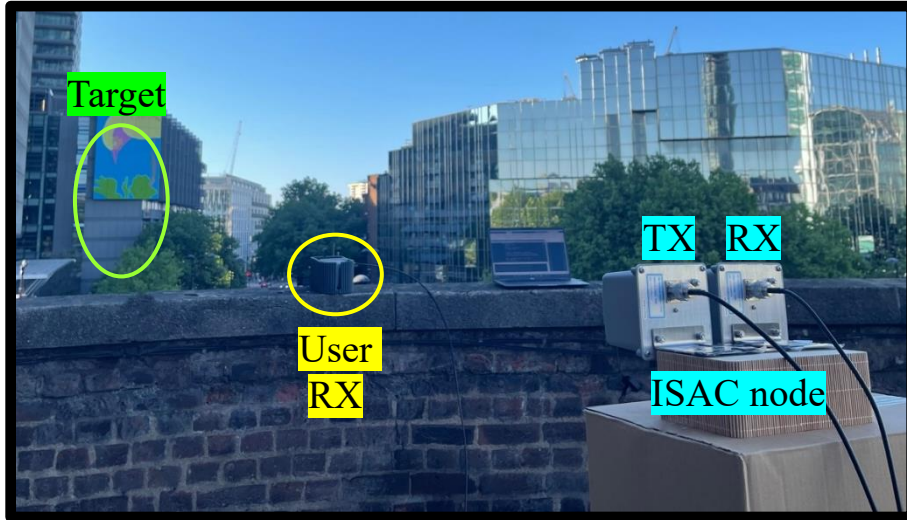

Measured Range Profiles

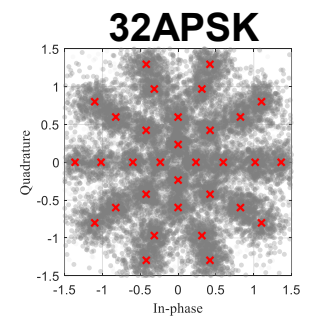
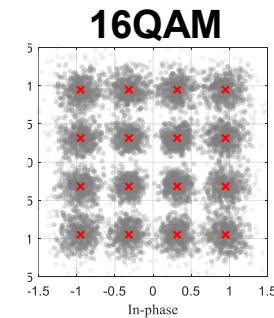
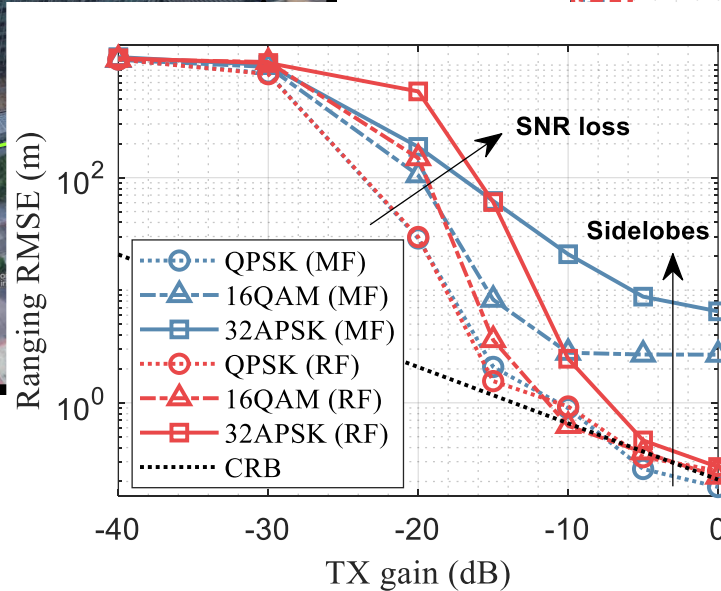
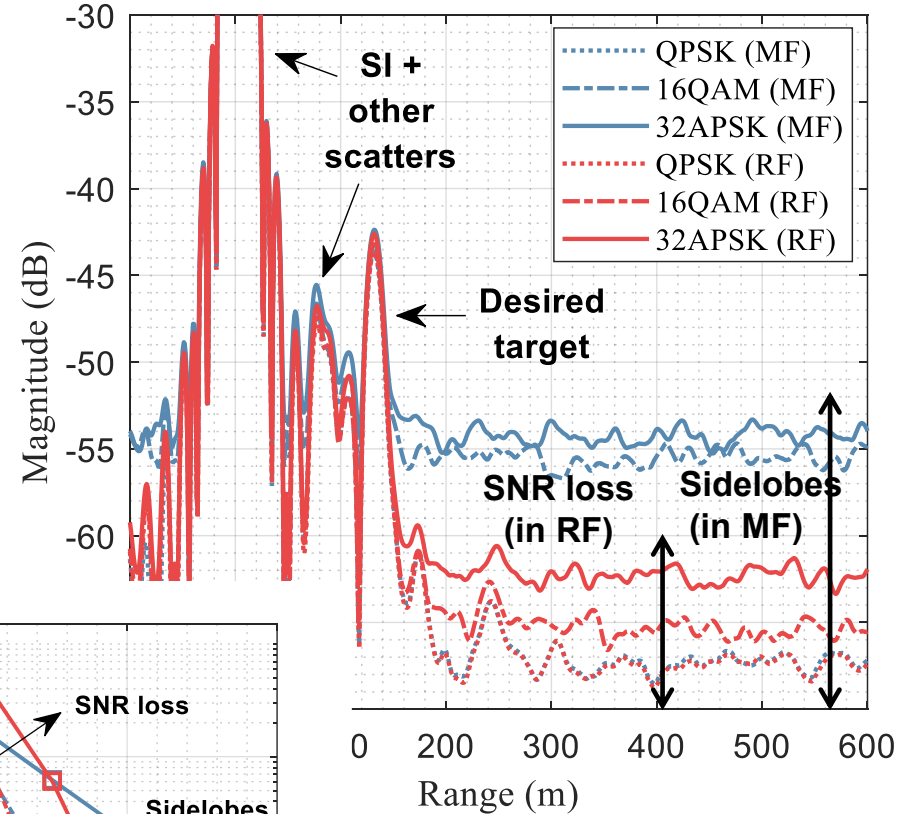

Minimum Euclidean distance vs. Ranging MSE Design

(P.1) μ_4 -based joint optimization for MF

$$\begin{aligned} & \text{minimize} && \rho \cdot \mu_4 + (1 - \rho) \cdot (-d_{min}) \\ & \mathcal{S} = \{s_1, s_2, \dots, s_M\} \\ & \text{subject to} && \mu_4 = \frac{1}{M} \sum_{i=1}^M |s_i|^4 \\ & && |s_i - s_j| \geq d_{min}, \forall s_i \neq s_j \in \mathcal{S} \\ & && \frac{1}{M} \sum_{i=1}^M |s_i|^2 = 1, \quad \frac{1}{M} \sum_{i=1}^M s_i^2 = 0 \quad \frac{1}{M} \sum_{i=1}^M s_i = 0 \end{aligned}$$

(P.2) ν_{-2} -based joint optimization for RF

$$\begin{aligned} & \text{minimize} && \rho \cdot \nu_{-2} + (1 - \rho) \cdot (-d_{min}) \\ & \mathcal{S} = \{s_1, s_2, \dots, s_M\} \\ & \text{subject to} && \nu_{-2} = \frac{1}{M} \sum_{i=1}^M |s_i|^{-2} \\ & && |s_i - s_j| \geq d_{min}, \forall s_i \neq s_j \in \mathcal{S} \\ & && \frac{1}{M} \sum_{i=1}^M |s_i|^2 = 1, \quad \frac{1}{M} \sum_{i=1}^M s_i^2 = 0 \quad \frac{1}{M} \sum_{i=1}^M s_i = 0 \end{aligned}$$

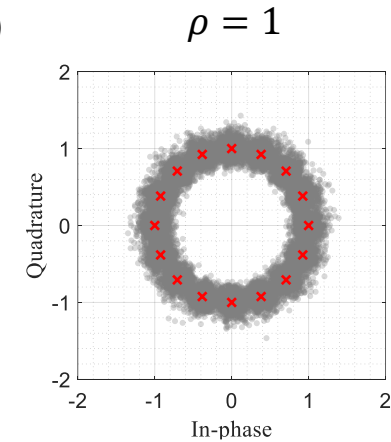
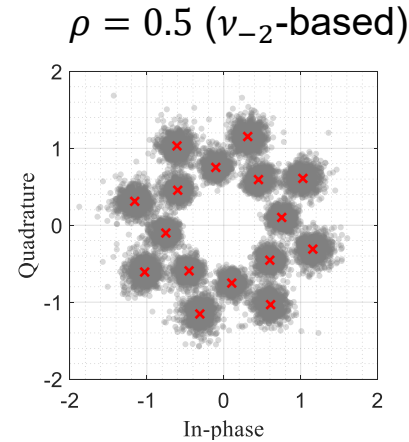
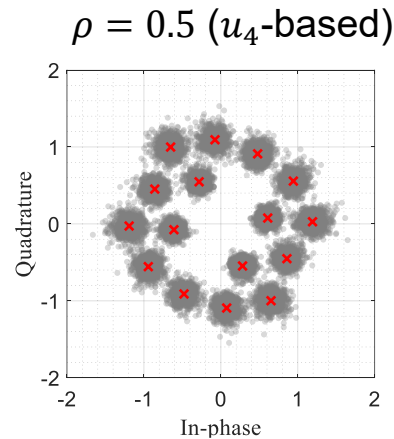
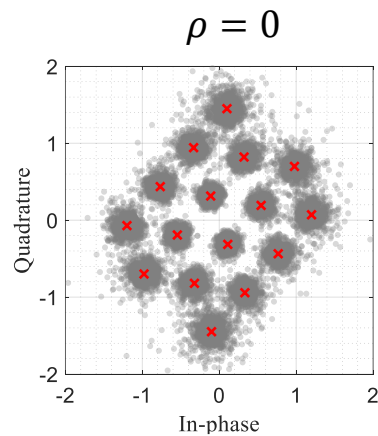

Sensing Range profiles w/ Matched Filtering

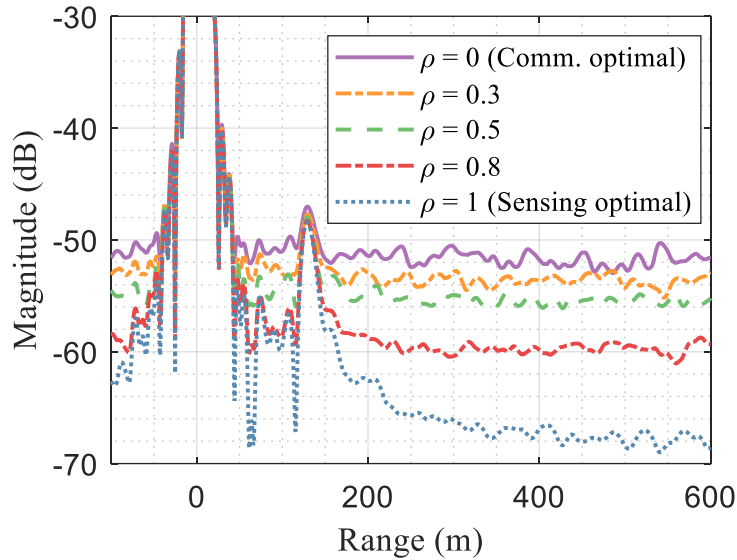

$$\text{Comms Throughput} = \log_2 M \cdot (1 - \text{BLER}) \cdot \left(\frac{N_s}{T_{\text{sym}} + T_{\text{cp}}} \right)$$

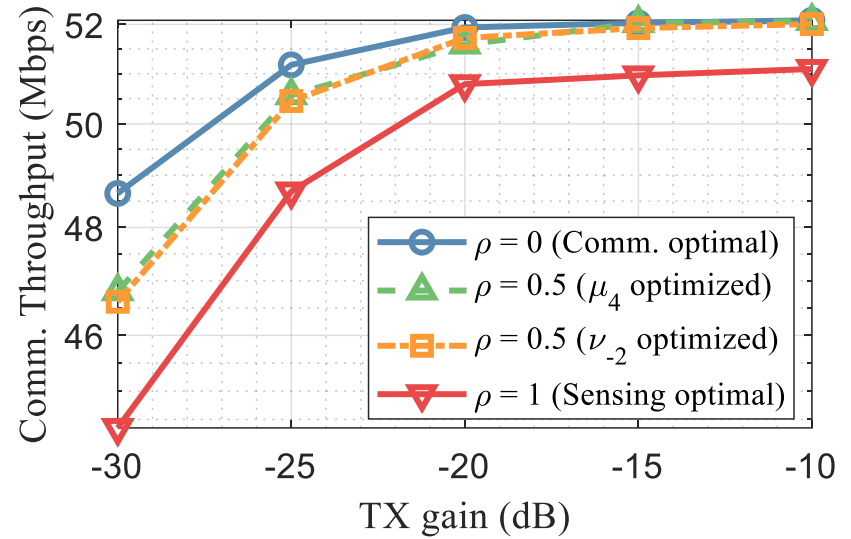

S & C trade-off (MF)

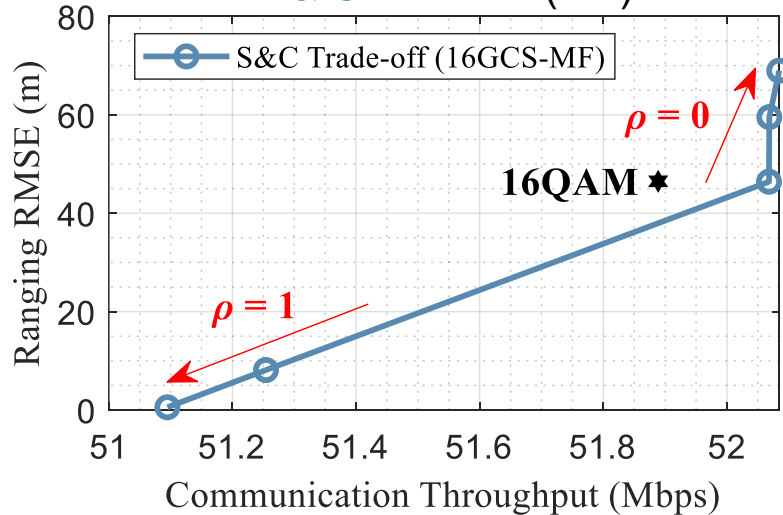

S & C trade-off (RF)

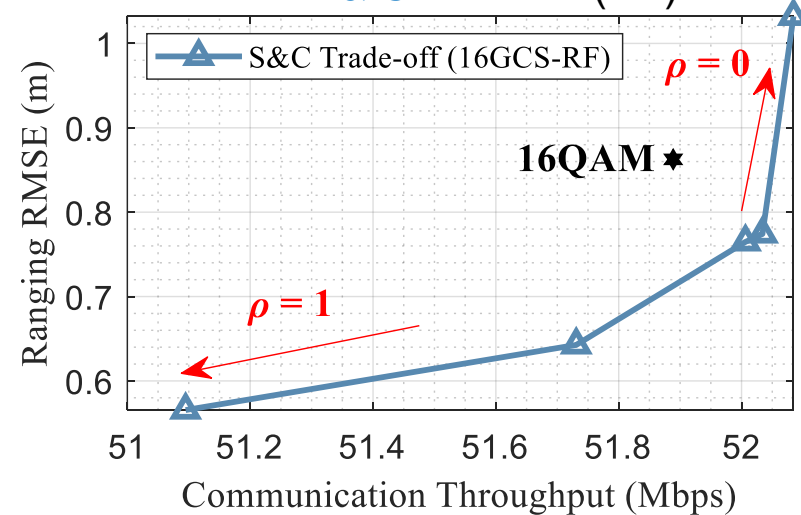

$$\min_{\mathbf{X}} \rho \|\mathbf{H}\mathbf{X} - \mathbf{S}\|_F^2 + (1 - \rho) \|\mathbf{X} - \underline{\mathbf{X}}_0\|_F^2$$

$$s.t. \quad \frac{1}{L} \|\mathbf{X}\|_F^2 = P_T,$$

Ideal radar waveform

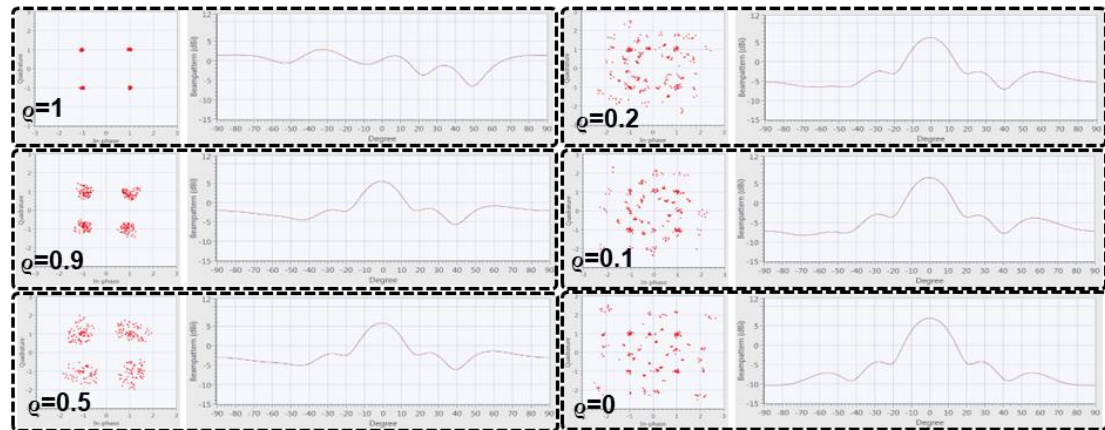
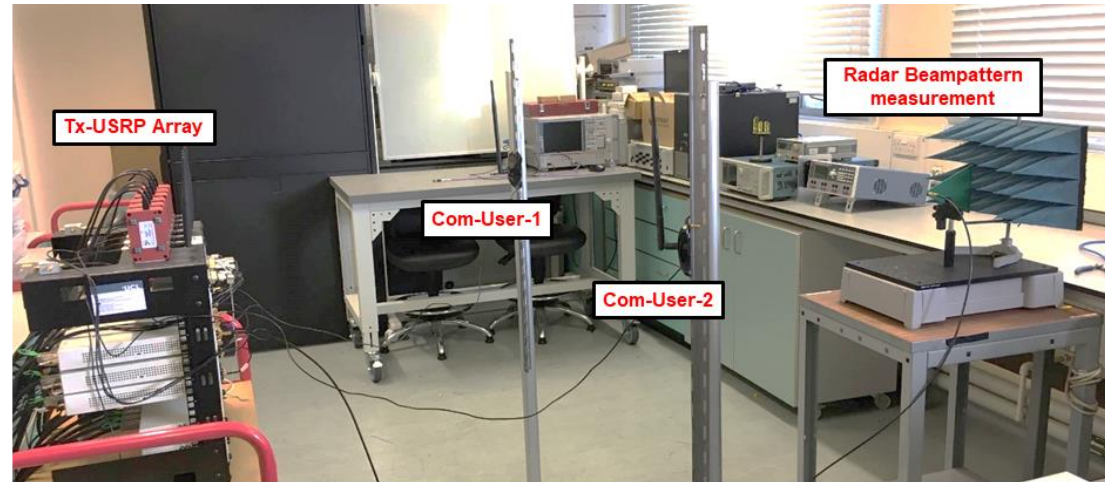
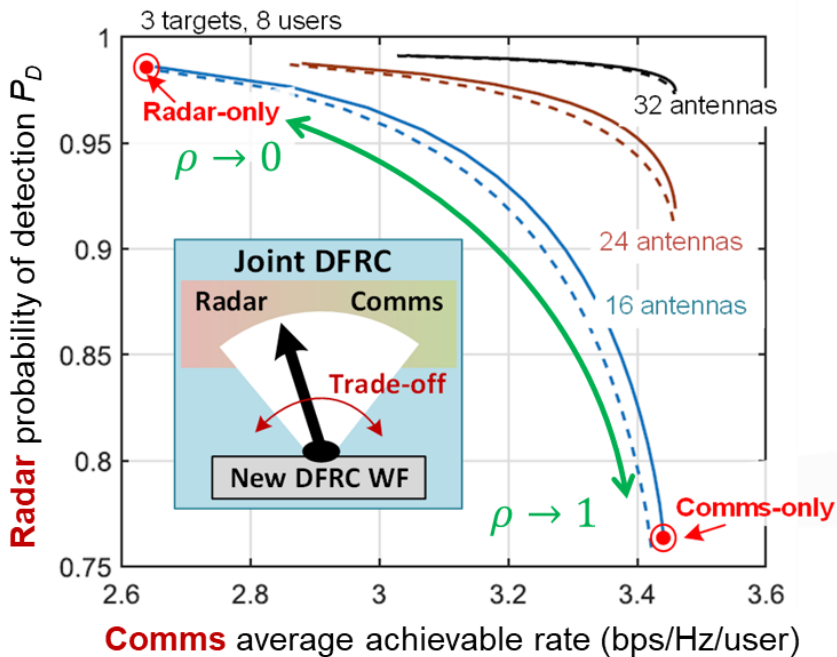

F. Liu, L. Zhou, C. Masouros, A. Li, W. Luo, and A. Petropulu, "Toward dual-functional radar-communication systems: Optimal waveform design," IEEE Trans. Signal Process., vol. 66, no. 16, pp. 4264–4279, Aug 2018.

T. Xu, F. Liu, C. Masouros, I. Darwazeh, "An Experimental Proof of Concept for Integrated sensing and Communications Waveform Design", IEEE Open Journal of ComSoc, vol. 3, pp. 1643-1655, 2022

Dual-functional Radar-Communication

Network Level Design

Coordination and Interference Nulling

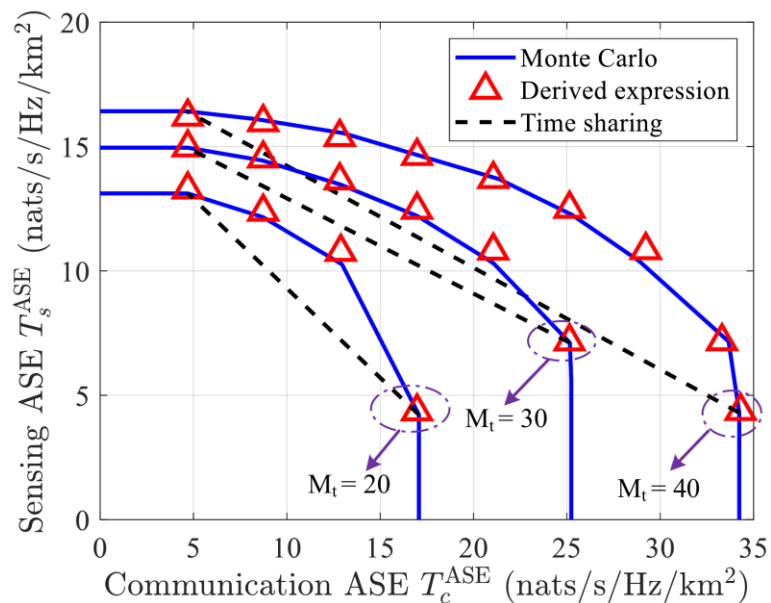
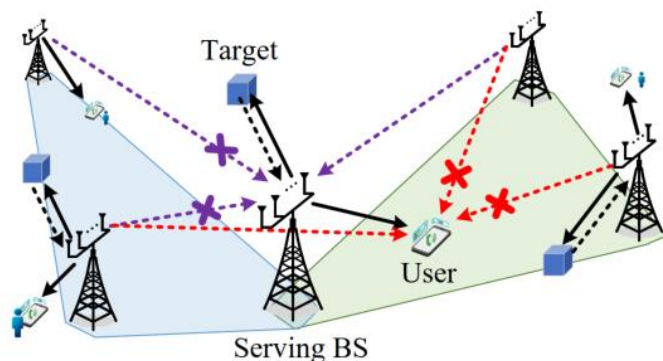

Cooperative Sensing – Cooperative Comms

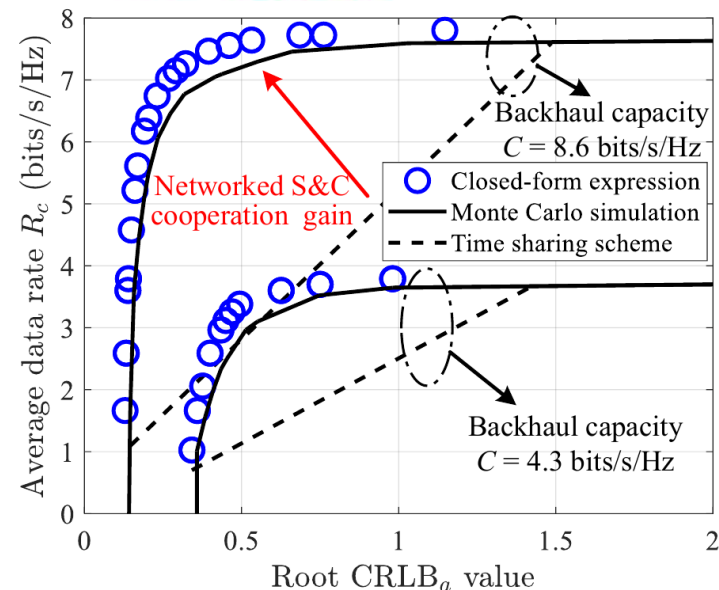
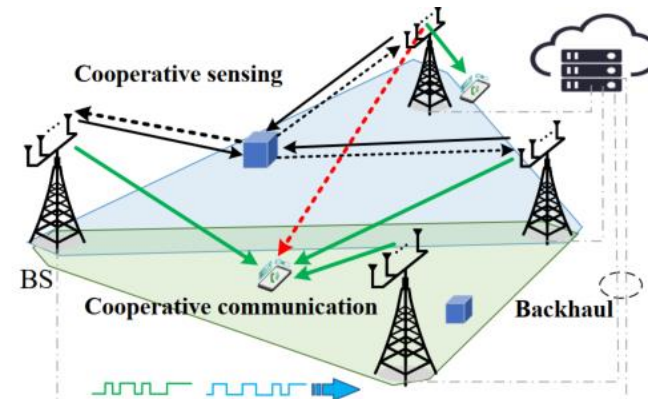

K. Meng, C. Masouros, et al., "Network-Level Integrated Sensing and Communication: Interference Management and BS Coordination Using Stochastic Geometry," IEEE Trans. Wireless Comms, vol. 23, no. 12, pp. 19365-19381, Dec. 2024

K. Meng, C. Masouros, A. Petropulu, L. Hanzo., "Cooperative ISAC Networks: Performance Analysis, Scaling Laws and Optimization," IEEE Trans. Wireless Comms, vol. 24, no. 2, pp. 877-892, Feb. 2025

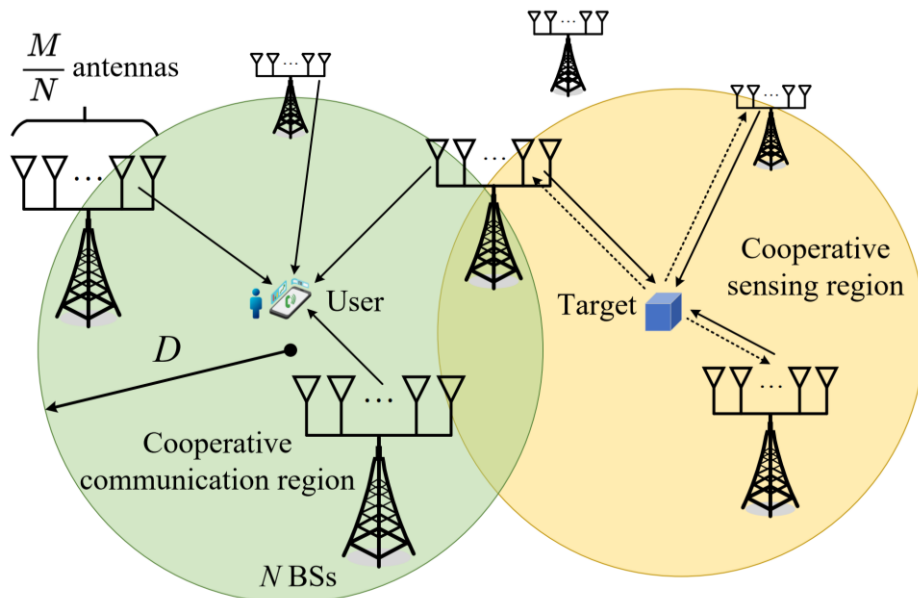

- TOF-based and hybrid localization → Cell-Free
 - Load closest antennas with high power
- AoA-based localization → semi-distributed
 - Use antenna array gain to establish high power

Massive MIMO or Cell-Free?

TOF-based target localization

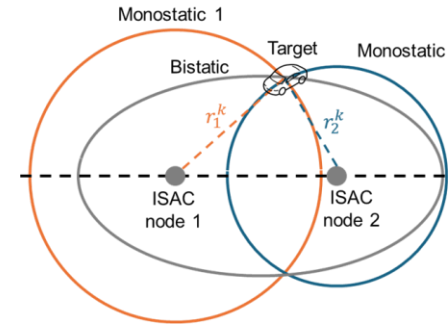

AOA-based

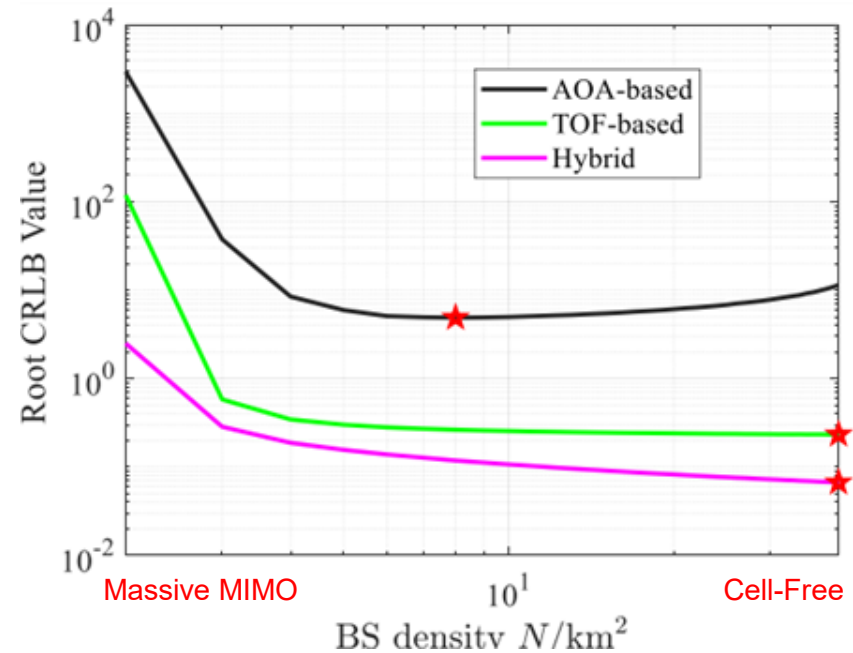
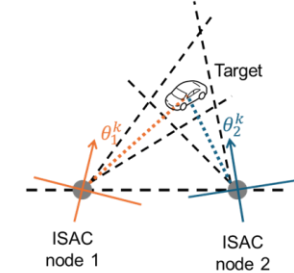

Network Level ISAC

Synchronisation

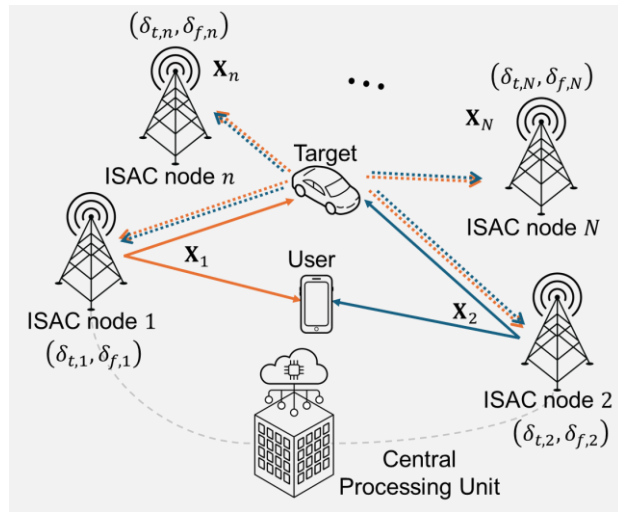

Constellation in **asynchronous** communication systems

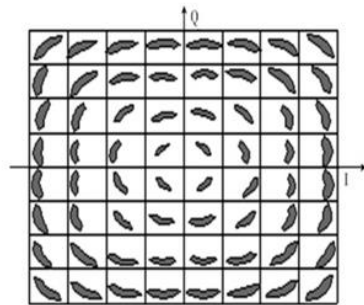

Noncoherent D-ISAC vs. Coherent D-ISAC

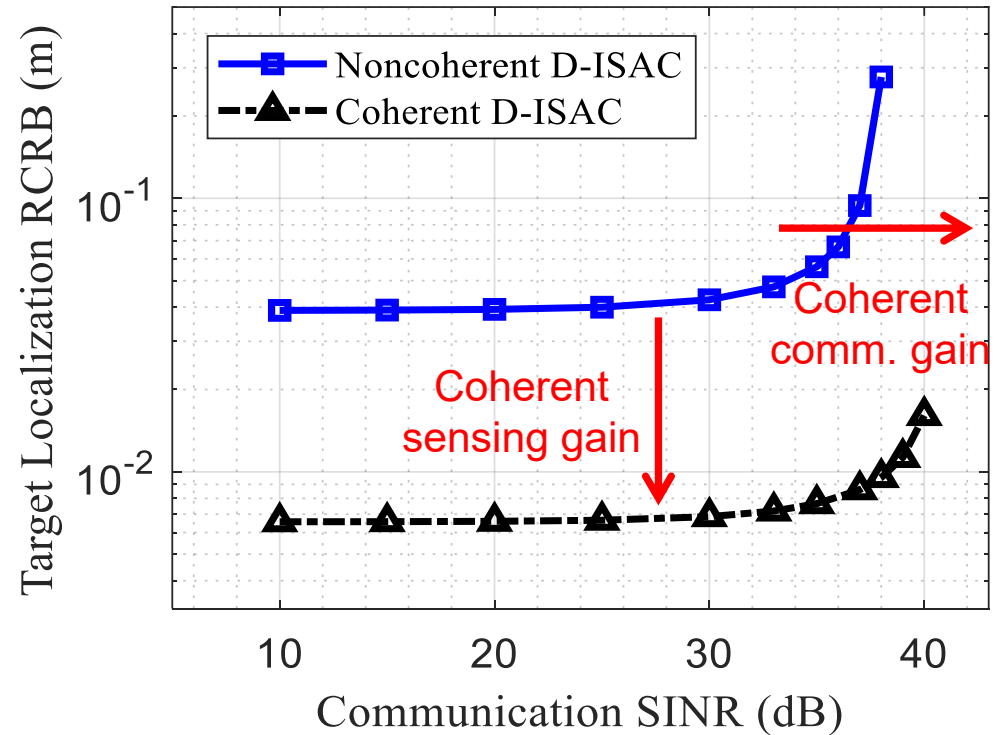

$$\check{\mathbf{Y}}_g = \sum_{l=1}^L e^{-j2\pi f_c \{ \boxed{\delta^f} + f_l^d \} [(g-1)T_s + T_c] + \boxed{\delta^r} + \tau_l \}} \alpha_l \mathbf{a}(\Omega_l^r) \mathbf{a}^T(\Omega_l^t) \boldsymbol{\omega} \boldsymbol{\tau}_l + \check{\mathbf{W}}_g,$$

Velocity ambiguity Range ambiguity

The cross-multipath cross-correlation (CMCC) synchronization

- Basic idea: find an ID of a specific environment - *fingerprint spectrum*
- Using the *fingerprint spectrum* as a reference in synchronization

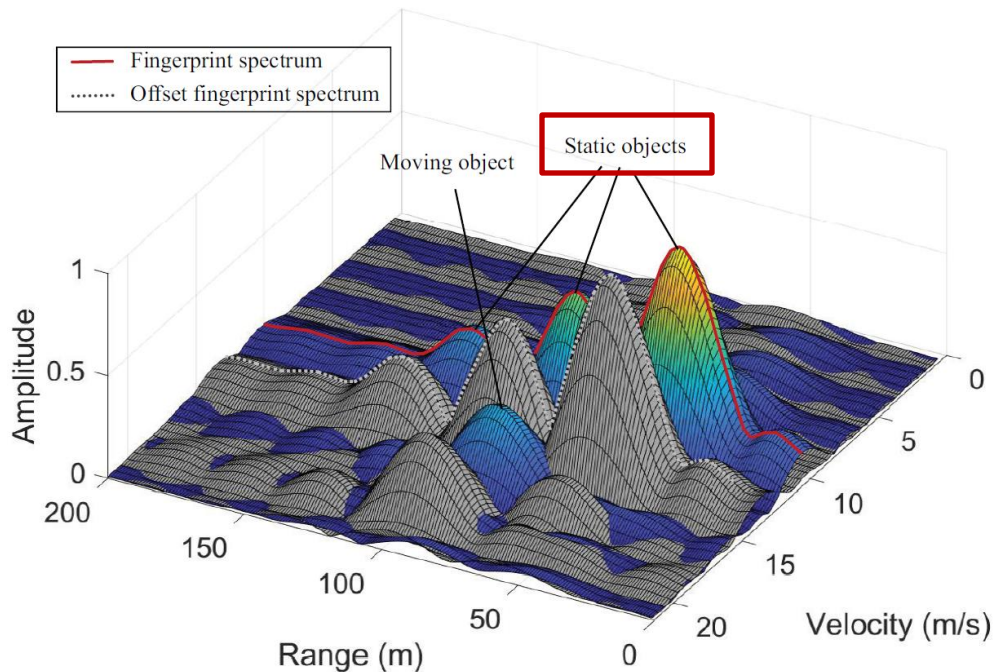

delay-Doppler spectrum of CSI

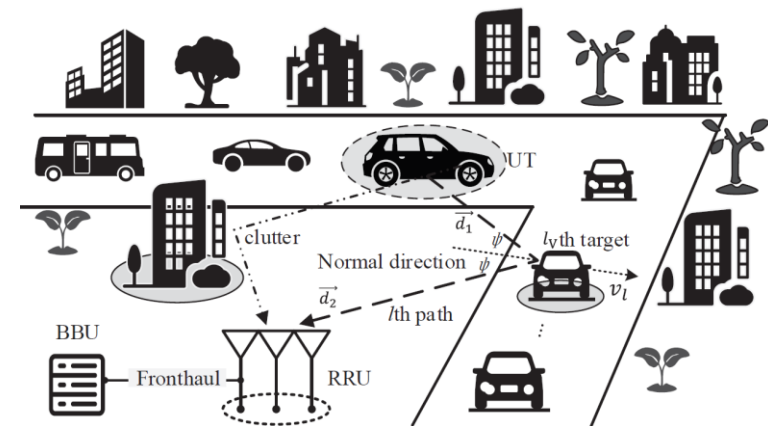

Environment

1) Centralized target localization ($N_1 + N_2$ processing)

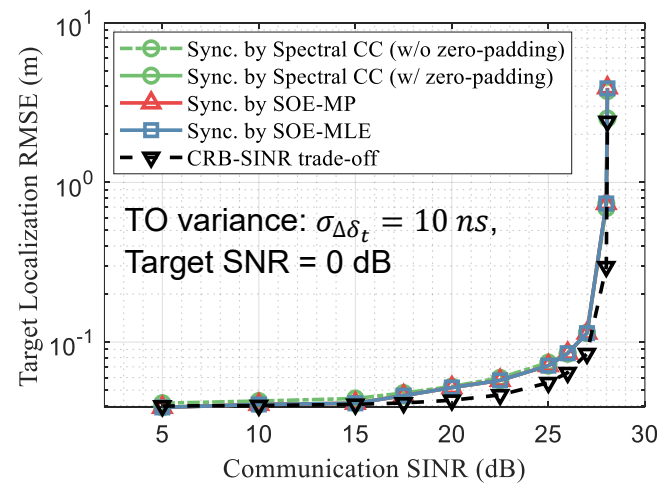
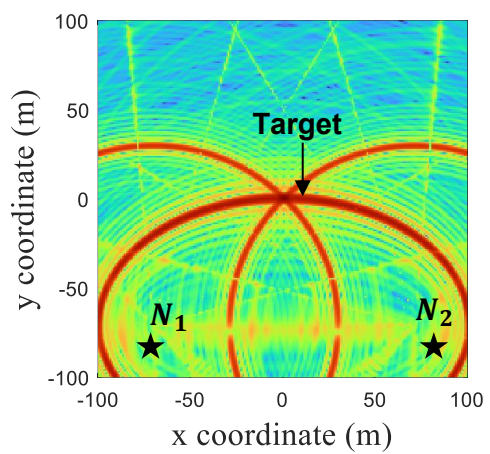

- Two monostatic links of N_1, N_2 compensate imperfect sync.
- Localization accuracy vs. comm. SNIR performance good for all sync approaches

CC: Spectral cross-correlation
 SOE: Super-resolution Offset Estimation
 MLE: Maximum likelihood
 MP: Matrix pencil

2) Decentralized target localization (only N_1 processing)

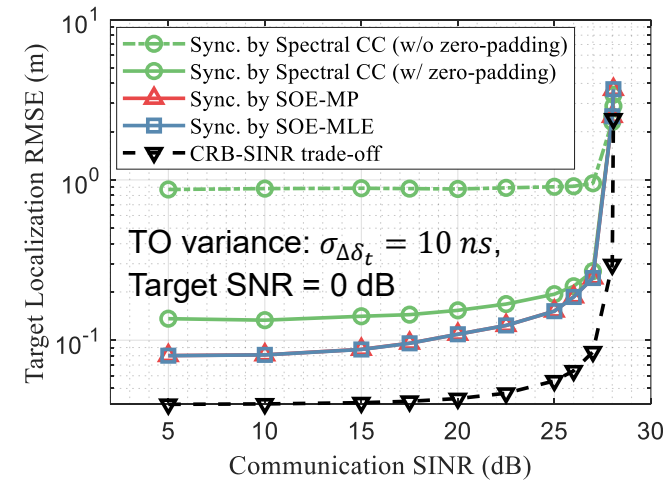
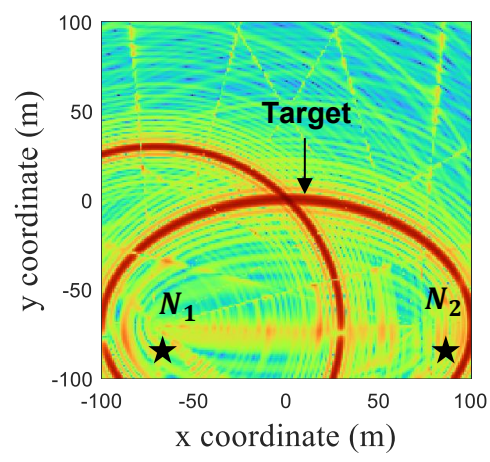

- Only N_1 monostatic link cannot compensate imperfect sync.
- \uparrow synchronization error \rightarrow
 \downarrow Localization accuracy
- **Sync approach matters**

Dual-functional Radar-Communication Subject to Security threats?

Unique Sensing Performance vs Security Trade-offs

- ↑ Power towards the direction of target
- ↓ Useful signal power (SINR) towards the target
- ↑ SINR towards the users

Opportunity: Exploit Sensing functionality to obtain knowledge of Eve

- Direction
- Channel
- $SINR_E$



Apply PHY Sec approaches

- ~~Secure BF~~
- AN, Jamming
- Cooperative Security
- ...

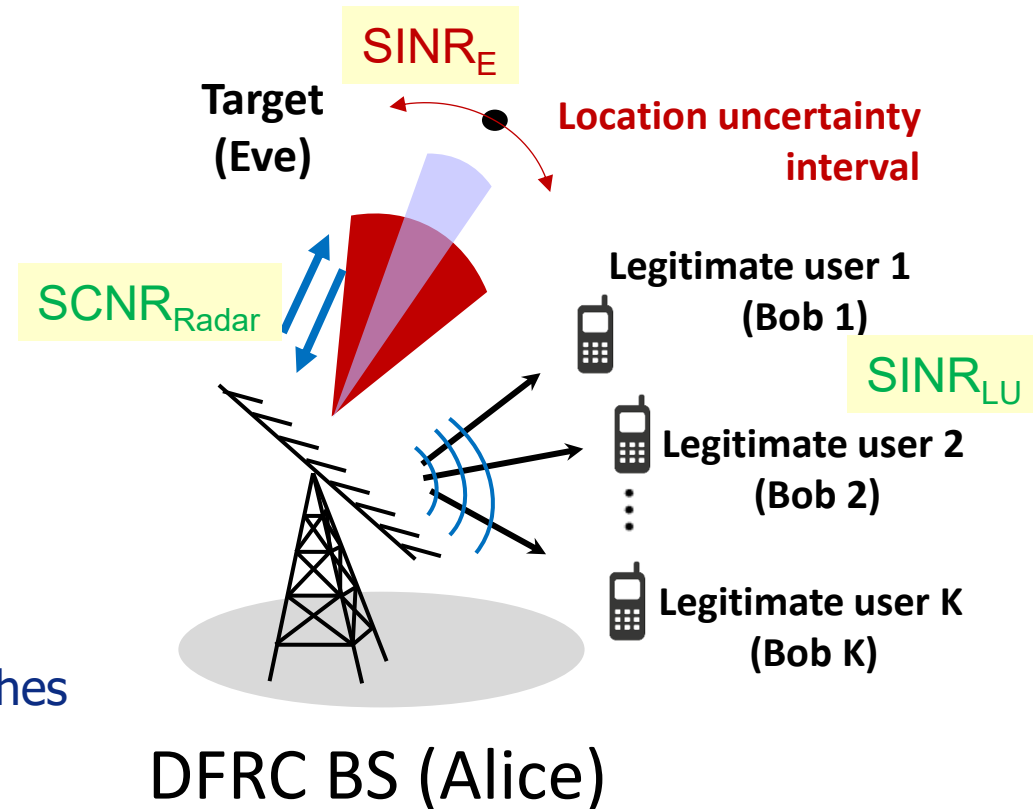

$N = 18$ antennas, $K = 4$ legitimate users, one target – LU SNR $\gamma_b = 10\text{dB}$.

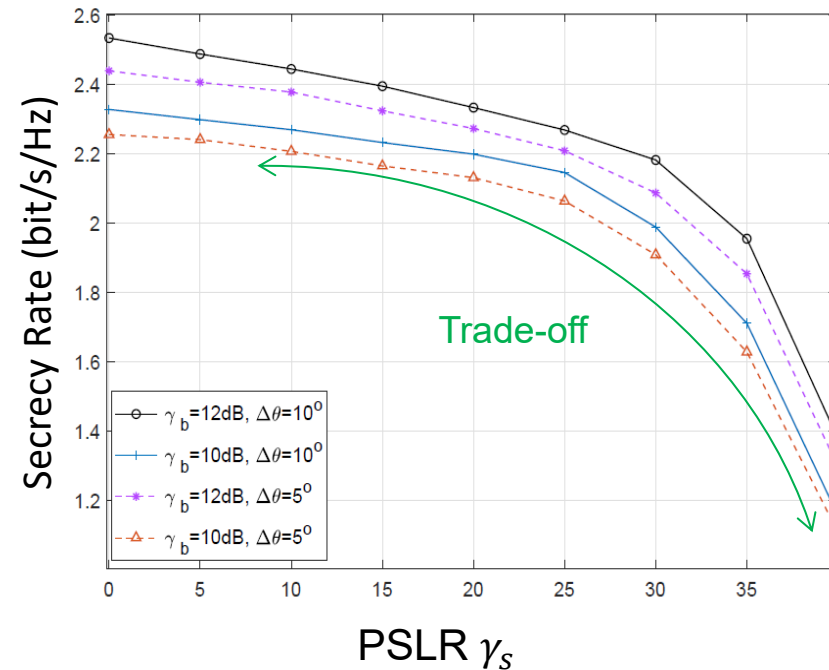
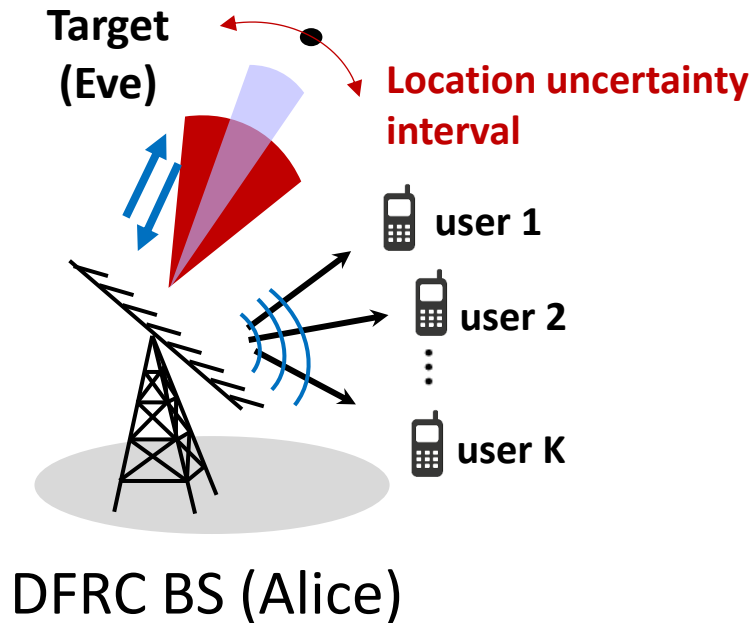

Secure DFRC Communication

Exploiting Subcarrier Interference

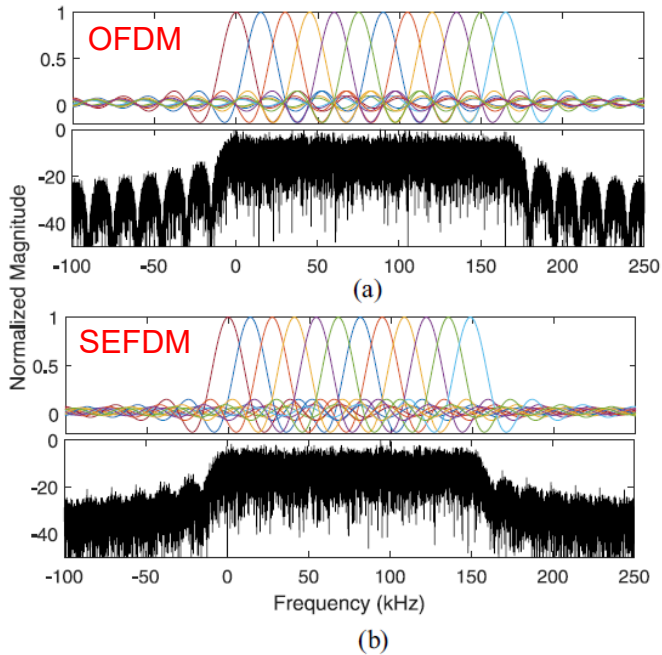

Compression factor $a = \Delta f \cdot T$

$$X_k = \frac{1}{\sqrt{N}} \sum_{n=1}^N s_n \exp\left(\frac{j2\pi nk\alpha}{N}\right) = \mathbf{F}\mathbf{S}$$

$$\mathbf{R} = \mathbf{F}^*(\mathbf{F}\mathbf{S} + \mathbf{Z}) = \mathbf{C}\mathbf{S} + \mathbf{F}^*\mathbf{Z} = \mathbf{C}\mathbf{S} + \mathbf{Z}_F^*$$

$$c_{m,n} = \frac{1}{N} \sum_{k=1}^N e^{\frac{j2\pi mk\alpha}{N}} e^{-\frac{j2\pi nk\alpha}{N}}$$

$$= \begin{cases} 1, & m = n \\ \frac{1 - e^{j2\pi\alpha(m-n)}}{N(1 - e^{\frac{j2\pi\alpha(m-n)}{N}})}, & m \neq n \end{cases}$$

$a = 0.9$, QPSK, $N_f=6$, $K=2$

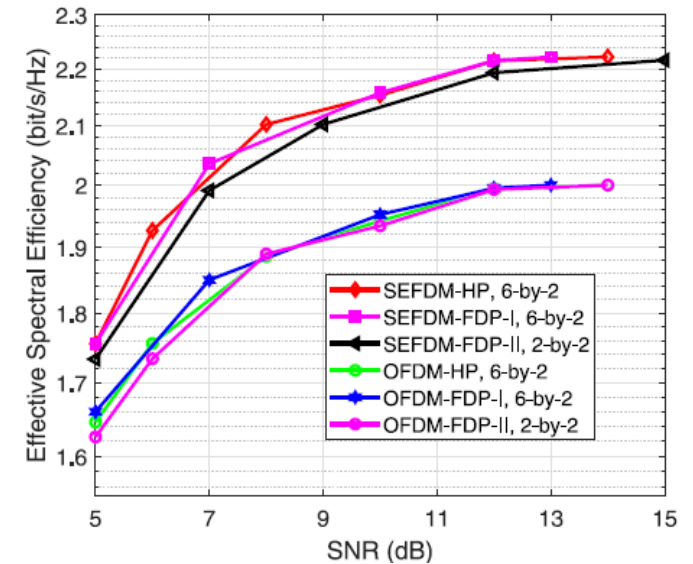

SEFDM: Controllable interference, that can be removed at Rx

ISAC trade-off for SEFDM

Security by SEFDM:

- Controllable interference, removable at legitimate Rx
- Non-resolvable at Eve

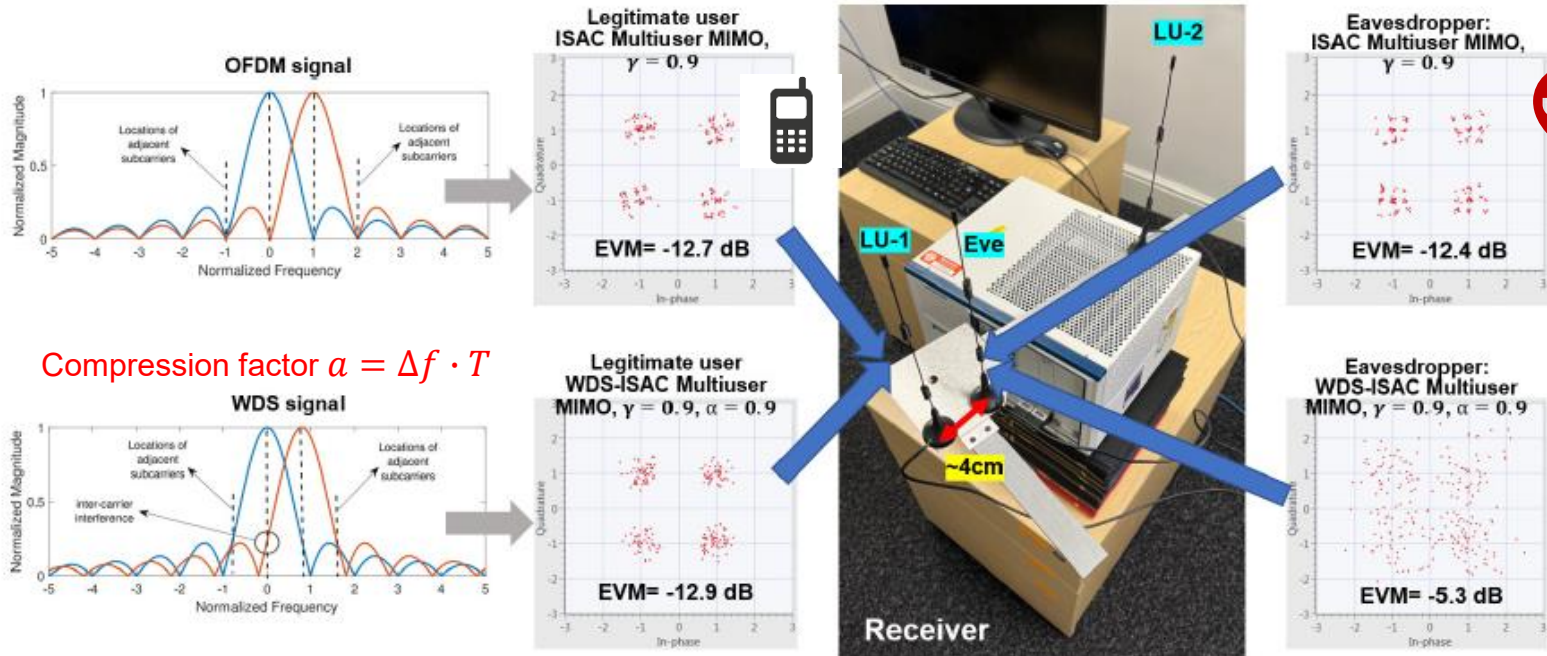
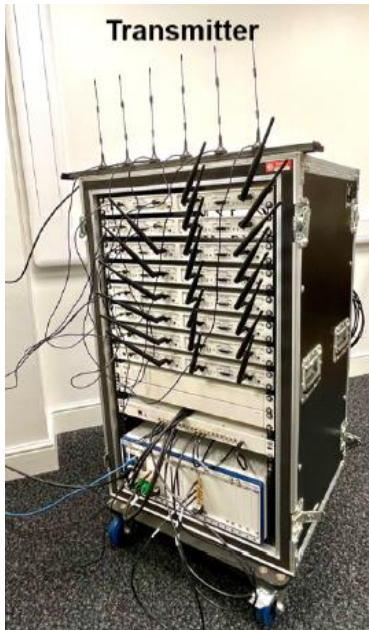
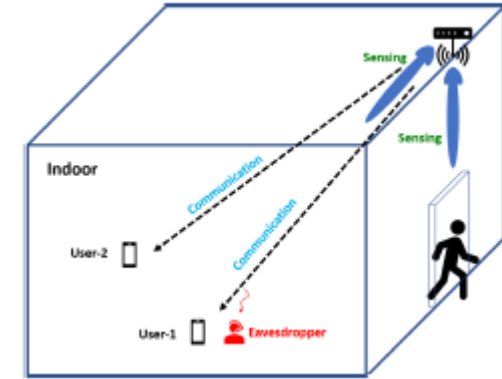
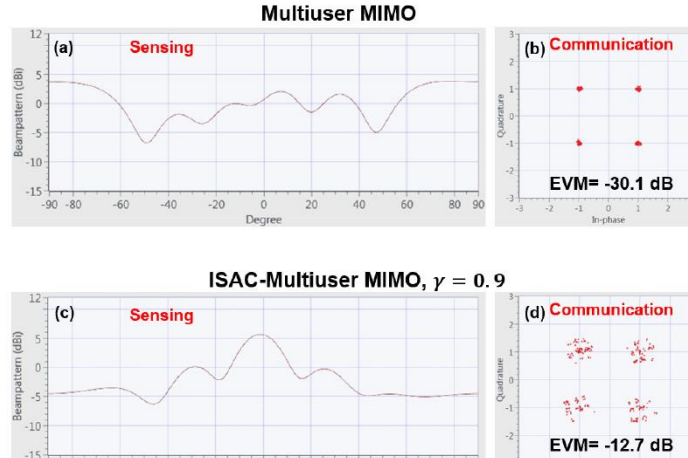

Secure Dual-functional Radar-Communication

**Exploiting Constructive / Destructive
Interference**

Constructive Interference Precoding

Key Concept: Exploitation of green interference power

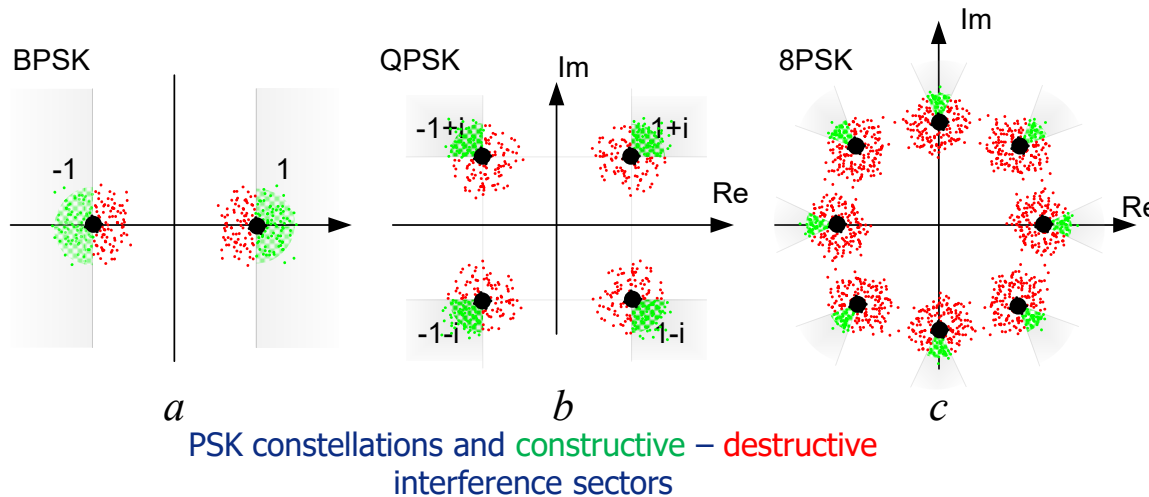

PSK constellations and constructive – destructive interference sectors

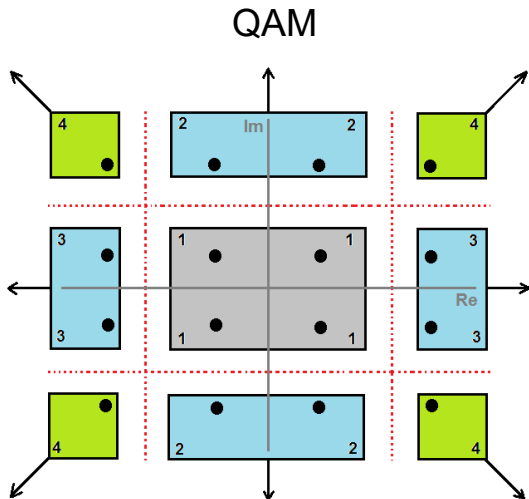

Up to 10x Power Reduction

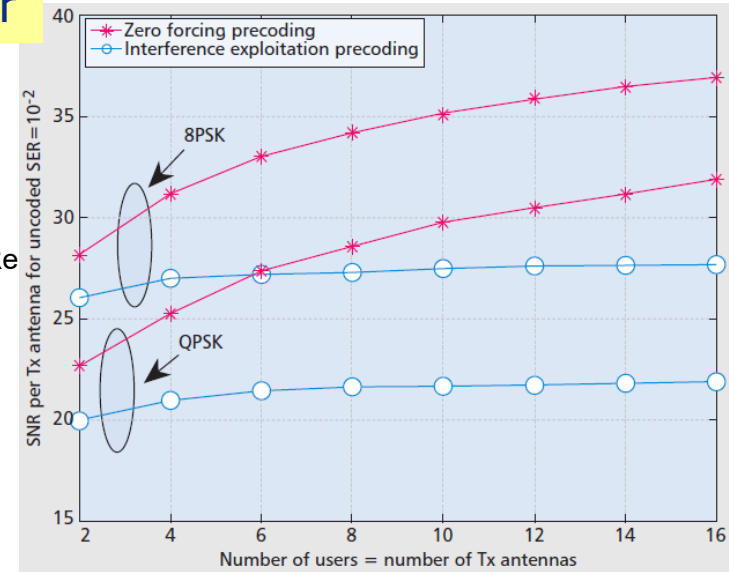

Early Works:

C. Masouros and E. Alsusa, "A Novel Transmitter-Based Selective-Precoding Technique for DS/CDMA systems", *IEEE Signal Processing letters*, vol. 14, no. 9, pp. 637-640, Sept. 2007

C. Masouros, "Correlation Rotation Linear Precoding for MIMO Broadcast Communications", *IEEE Trans. on Sig. Proc.*, vol 59, issue 1, pp. 252-262, Jan 2011

C. Masouros, T. Ratnarajah, M. Sellathurai, C. Papadias, A. Shukla, "Known Interference in Wireless Communications: A Limiting factor or a Potential Source of Green Signal Power?", *IEEE Comms. Mag.*, vol. 51, no. 10, pp. 162-171, Oct. 2013

C. Masouros, M. Sellathurai, T. Ratnarajah, "Interference Optimization for Transmit Power Reduction in Tomlinson-Harashima Precoded MIMO Downlinks", *IEEE Trans. Sig. Proc.*, vol. 60, no. 5, pp. 2470-2481, May 2012

C. Masouros, M. Sellathurai, T. Ratnarajah, "Vector Perturbation Based on Symbol Scaling for Limited Feedback MIMO Downlinks", *IEEE Trans. Sig. Proc.*, vol. 62, no. 3, pp. 562-571, Feb.1, 2014

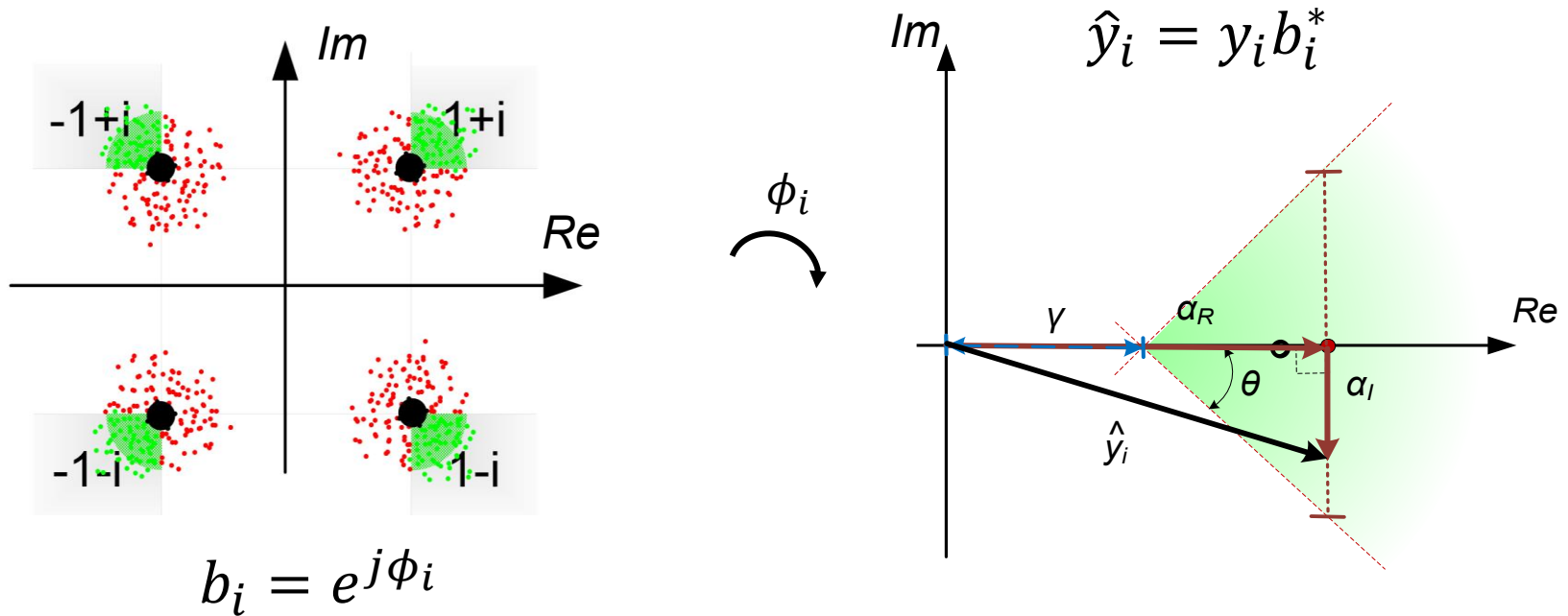

Constructive Interference:

- $a_R \geq \gamma$

- $|\alpha_I| \leq (\alpha_R - \gamma) \tan \theta$

$$\alpha_R = \text{Re}(\hat{y}_i), \alpha_I = \text{Im}(\hat{y}_i)$$

$$\theta = \frac{\pi}{M}, \gamma = \sqrt{\Gamma_i N_0}$$

C. Masouros and G. Zheng, "Exploiting Known Interference as Green Signal Power for Downlink Beamforming Optimization", IEEE Trans. Sig. Proc., vol.63, no.14, pp.3668-3680, July, 2015

A. Li, *et. al*, "A Tutorial on Interference Exploitation via Symbol-Level Precoding: Overview, State-of-the-Art and Future Directions", IEEE Comms. Surveys and tutorials., vol. 22, no. 2, pp. 796-839, 2020

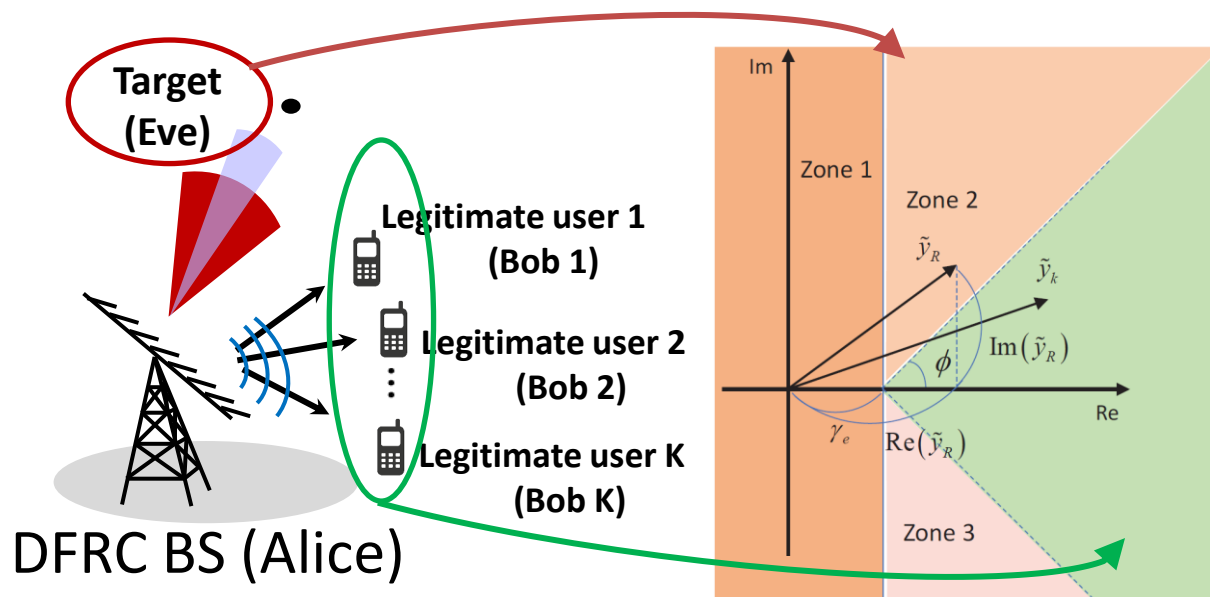

$$\max_{\mathbf{x}} \min_{\theta_p \in \text{card}(\Psi)} \frac{\mu |\mathbf{w}^H \mathbf{U}(\theta_p) \mathbf{x}|^2}{\mathbf{w}^H (\mathbf{\Sigma}(\mathbf{x}) + \mathbf{I}_{N_R}) \mathbf{w}} \quad (38a)$$

← Radar SNR

$$\text{s.t. } \|\mathbf{x}\|^2 \leq P_0 \quad (38b)$$

$$|\text{Im}(\tilde{\mathbf{h}}_k^H \mathbf{x})| \leq \left(\text{Re}(\tilde{\mathbf{h}}_k^H \mathbf{x}) - \sqrt{\sigma_{C_k}^2 \Gamma_k} \right) \tan \phi, \forall k \quad (38c)$$

← Constructive interference to users

$$|\text{Im}(\alpha_0 \tilde{\mathbf{a}}_t^H(\beta_p) \mathbf{x})| \geq \left(\text{Re}(\alpha_0 \tilde{\mathbf{a}}_t^H(\beta_p) \mathbf{x}) - \sqrt{\sigma_T^2 \Gamma_T} \right) \tan \phi, \forall p, \quad (38d)$$

← Destructive interference to target (Eve)

$N = 10$ antennas, $K = 5$ legitimate users, one target.

Signal Constellations at users / target

Constructive interference

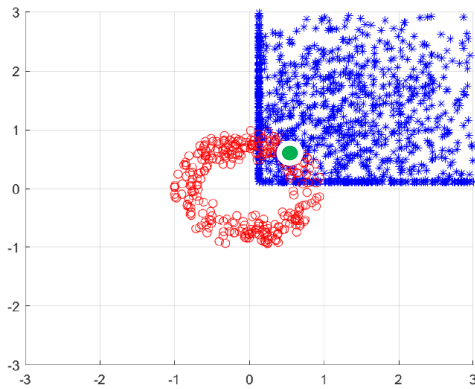

(a) QPSK, CI

Constructive - Destructive interference

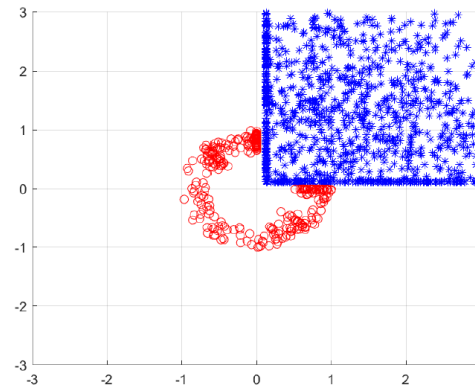

(b) QPSK, CI-DI

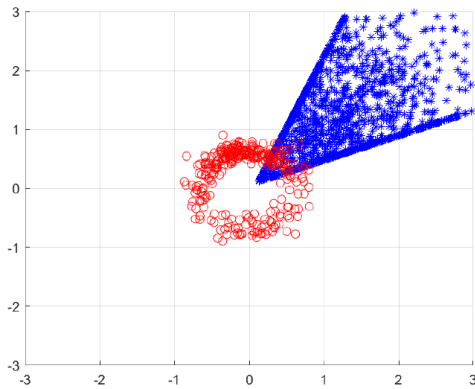

(c) 8PSK, CI

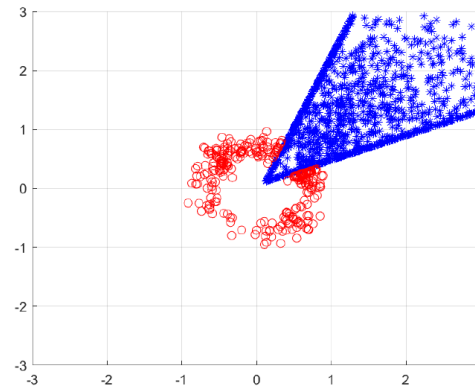

(d) 8PSK, CI-DI

Radar beampattern

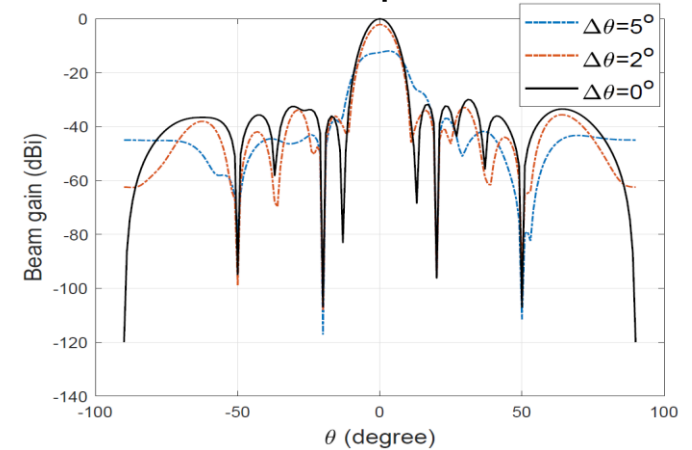

SER at users / target

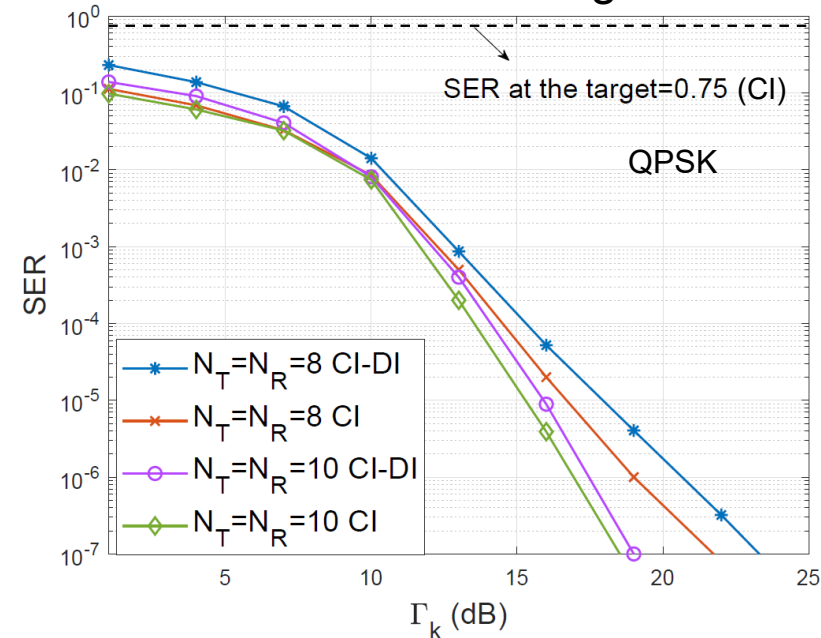

Sensing Security

Eve-Aware Approach

$\mathbf{X} = \mathbf{W}\mathbf{S}$ (\mathbf{W} : beamforming matrix; \mathbf{S} : symbol matrix)

Mutual information with perfectly known reference signal

Legitimate receiver: $I_r(\mathbf{Y}_r; \mathbf{H}_{tr} | \mathbf{X}) = \log \det(\mathbf{I} + \sigma_r^{-2} \mathbf{R}_{h_r} (\mathbf{X}^* \mathbf{X}^T \otimes \mathbf{I}_{N_r}))$

Eavesdropper: $I_e(\mathbf{Y}_e; \mathbf{H}_e | \mathbf{X}) = \log \det(\mathbf{I} + \sigma_e^{-2} L \Lambda_e \sum_{i=1}^{N_e} \mathbf{Q}_i \mathbf{R}_{\mathbf{X}}^* \mathbf{Q}_i^H)$

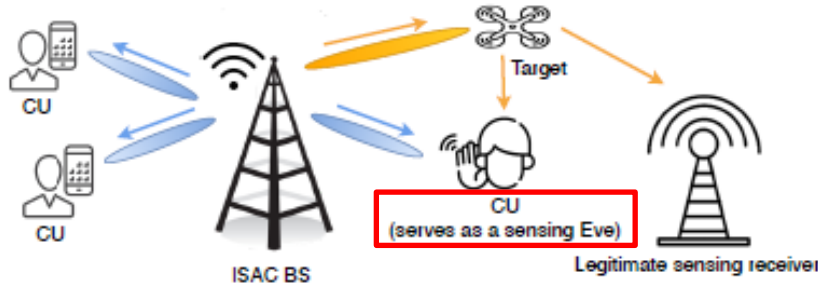

$$\begin{aligned} \max_{\{\mathbf{W}_k\}_{k=1}^K} I_r &= \log \det \left(\mathbf{I} + \sigma_r^{-2} L \Lambda_r \sum_{i=1}^{N_r} \mathbf{P}_i \mathbf{R}_{\mathbf{X}}^* \mathbf{P}_i^H \right) \\ \text{s.t. } I_e &= \log \det \left(\mathbf{I} + \sigma_e^{-2} L \Lambda_e \sum_{i=1}^{N_e} \mathbf{Q}_i \mathbf{R}_{\mathbf{X}}^* \mathbf{Q}_i^H \right) \leq \epsilon, \\ \text{tr}(\mathbf{R}_{\mathbf{X}}) &\leq P_0, \\ \frac{\text{tr}(\mathbf{h}_k \mathbf{W}_k \mathbf{h}_k^H)}{\sum_{k=1, k \neq i}^K \text{tr}(\mathbf{h}_k \mathbf{W}_i \mathbf{h}_k^H) + \sigma_c^2} &\geq \gamma_k, \forall k, \\ \mathbf{R}_{\mathbf{X}} &= \sum_{k=1}^K \mathbf{W}_k, \mathbf{W}_k \succeq 0, \text{rank}(\mathbf{W}_k) = 1, \forall k, \end{aligned}$$

$\Lambda_r, \mathbf{P}_i \leftarrow$ Eigendecomposition of \mathbf{R}_{h_r}

$\Lambda_e, \mathbf{Q}_i \leftarrow$ Eigendecomposition of \mathbf{R}_{h_e}

$N_t: 6, \text{SNR}_{\text{com}} = 28\text{dB}, K=3, 1 \text{ target}$

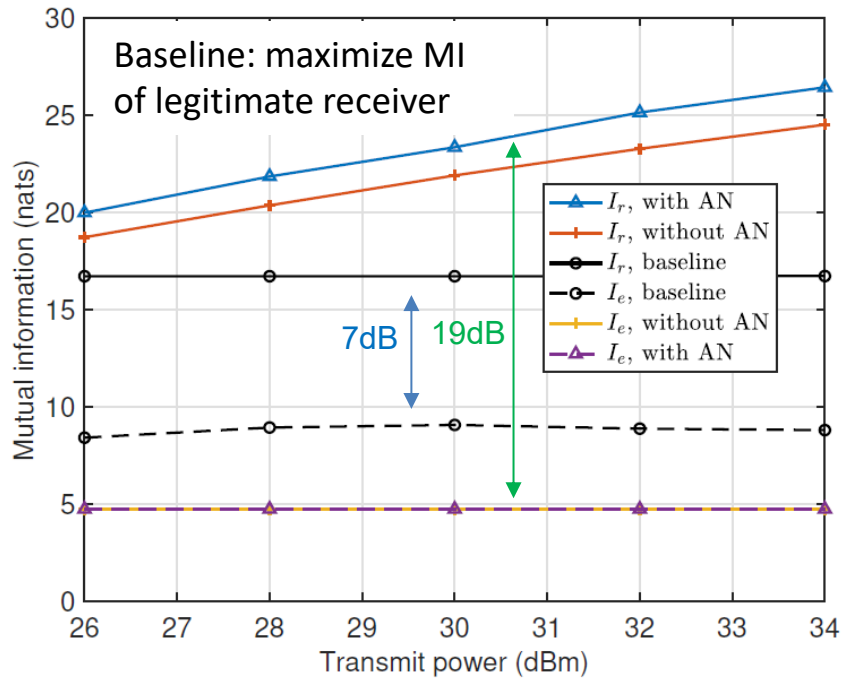

$N_t: 6, P_t = 30\text{dBm}, K=3, 1 \text{ target}$

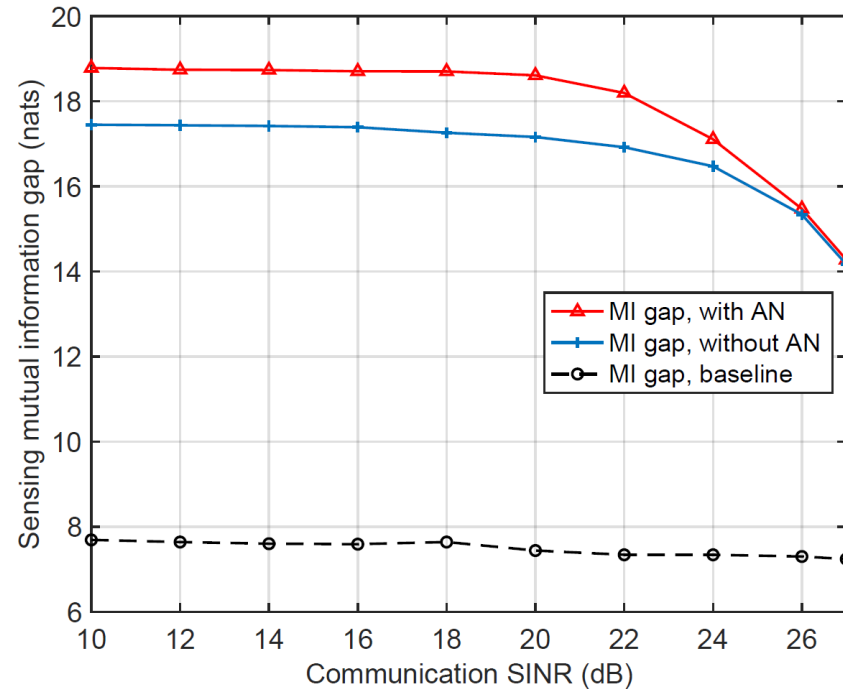

- MI Gap increases with secure sensing transmission
- Trade-off between **Secure Sensing** vs **Comms** performance

Sensing Security

Eve-Agnostic Approaches

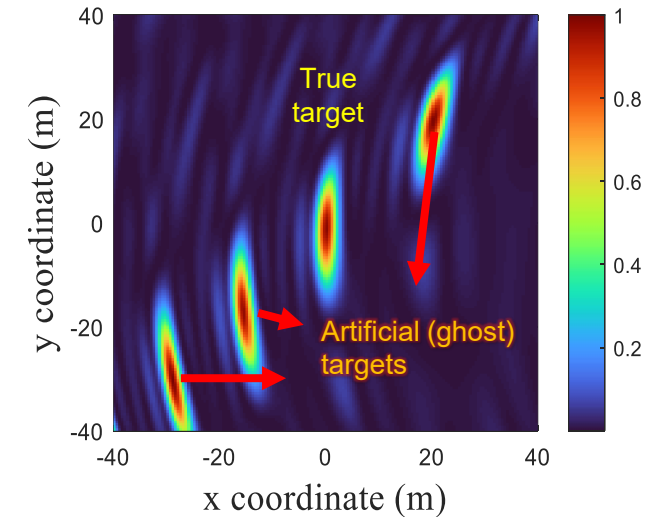
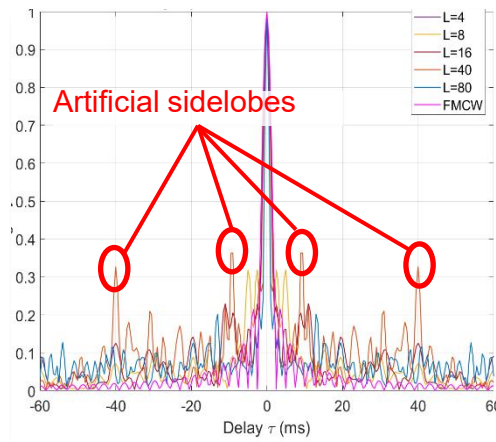
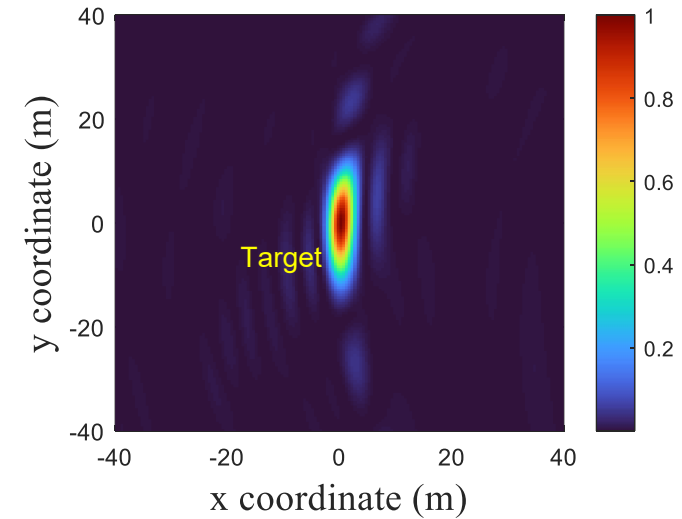
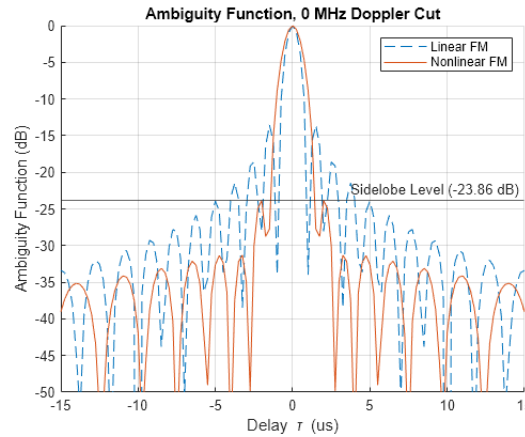
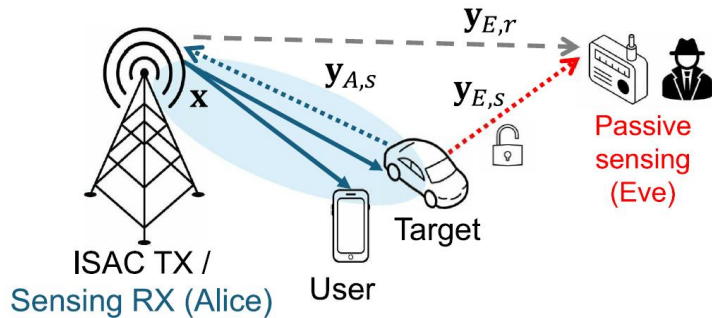

K. Han, C. Masouros, "methods and apparatus for preventing unauthorized sensing", patent filed

K. Han, K. Meng, C. Masouros, "Sensing-Secure ISAC: Ambiguity Function Engineering for Impairing Unauthorized Sensing" IEEE Trans Wireless Comm, vol. 25, pp. 5386-5400, 2026

Sensing Security

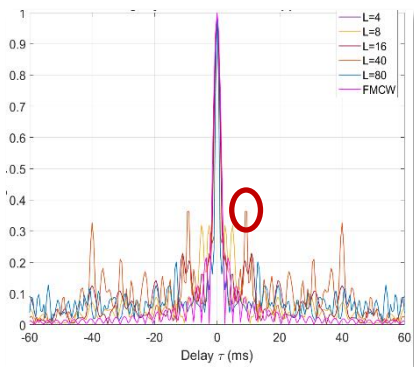
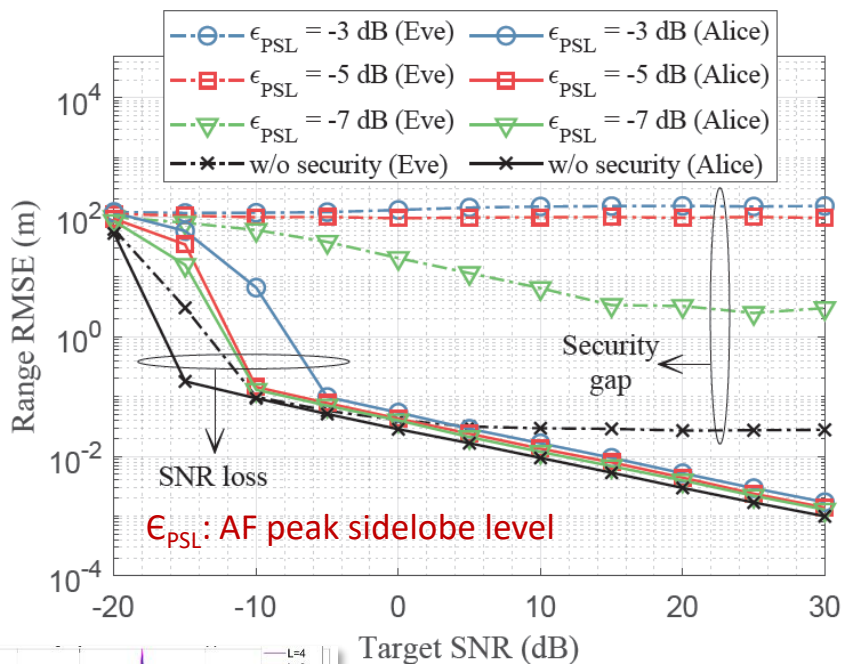

Sensing Security vs Comms trade-off

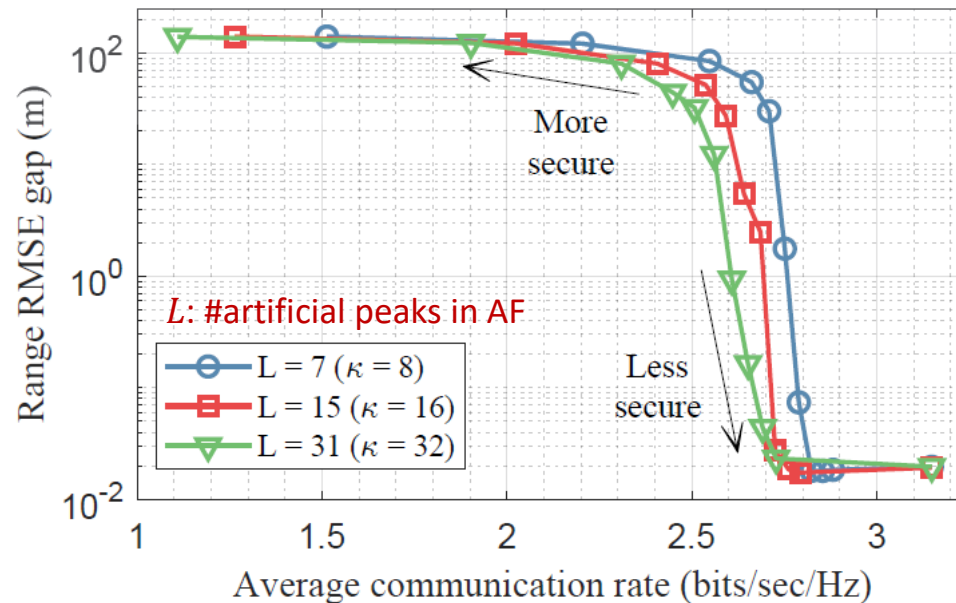

- RMSE Gap increases with PSL level
- RMSE Gap increases with #artificial peaks in AF
- Trade-off between **Secure Sensing** vs **Comms** performance

K. Han, C. Masouros, "methods and apparatus for preventing unauthorized sensing", patent filed

K. Han, K. Meng, C. Masouros, "Sensing-Secure ISAC: Ambiguity Function Engineering for Impairing Unauthorized Sensing" IEEE Trans Wireless Comm, vol. 25, pp. 5386-5400, 2026

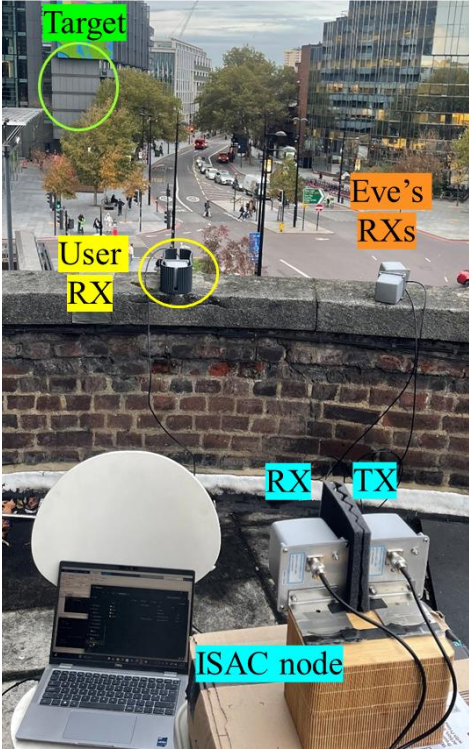

Sensing Security

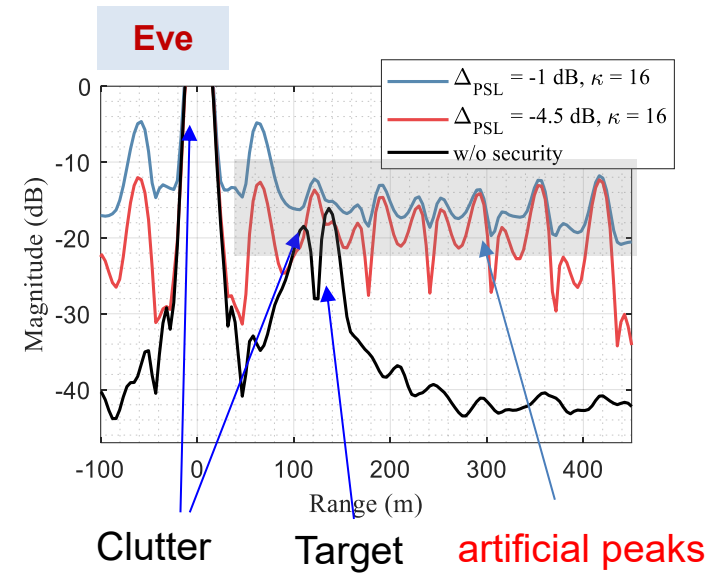
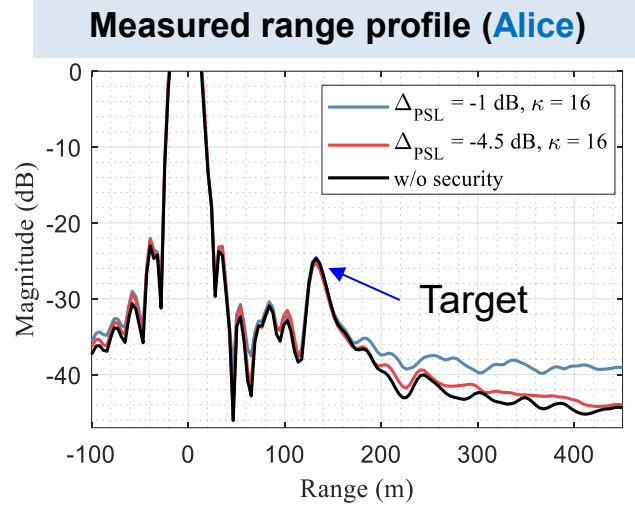

Communications

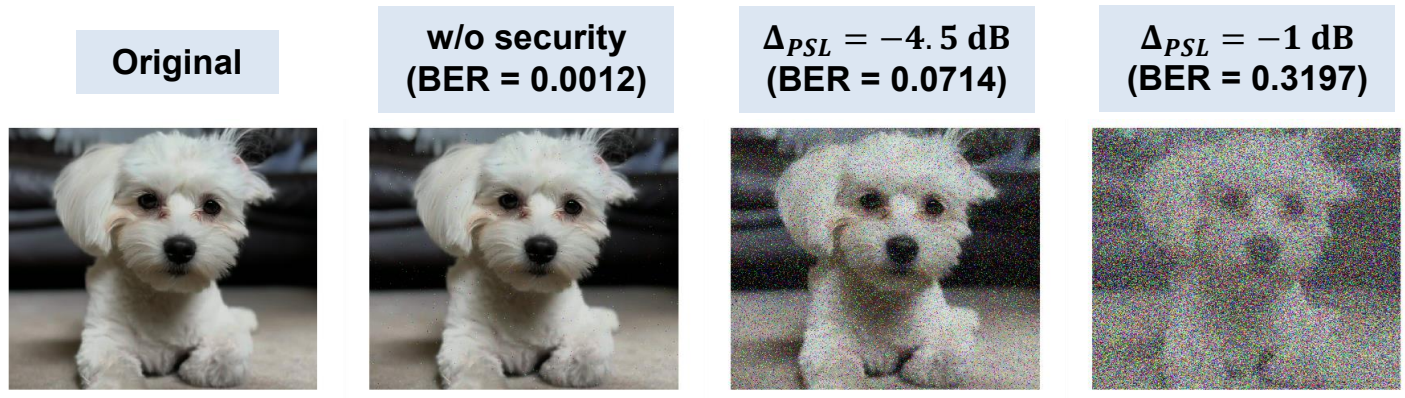

K. Han, C. Masouros, "methods and apparatus for preventing unauthorized sensing", patent filed

K. Han, K. Meng, C. Masouros, "Sensing-Secure ISAC: Ambiguity Function Engineering for Impairing Unauthorized Sensing" IEEE Trans Wireless Comm, vol. 25, pp. 5386-5400, 2026

Secure Sensing

Exploiting Clutter

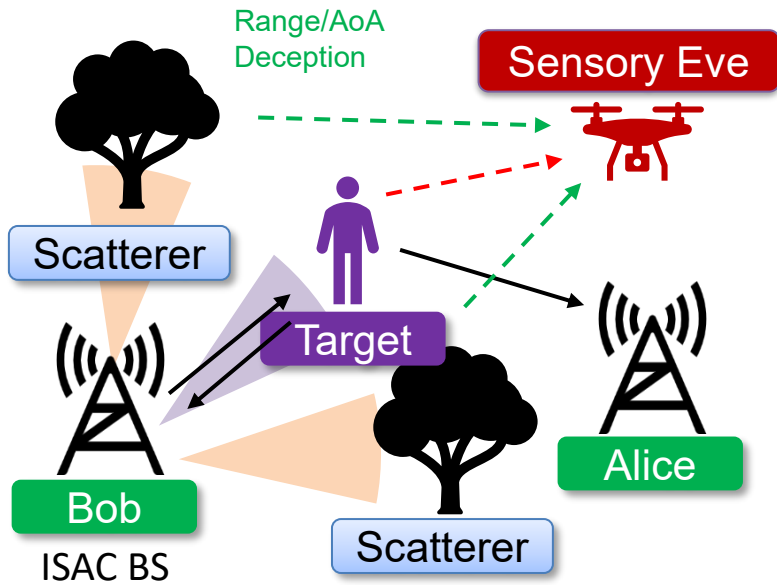

Flexible Transmit Beampattern

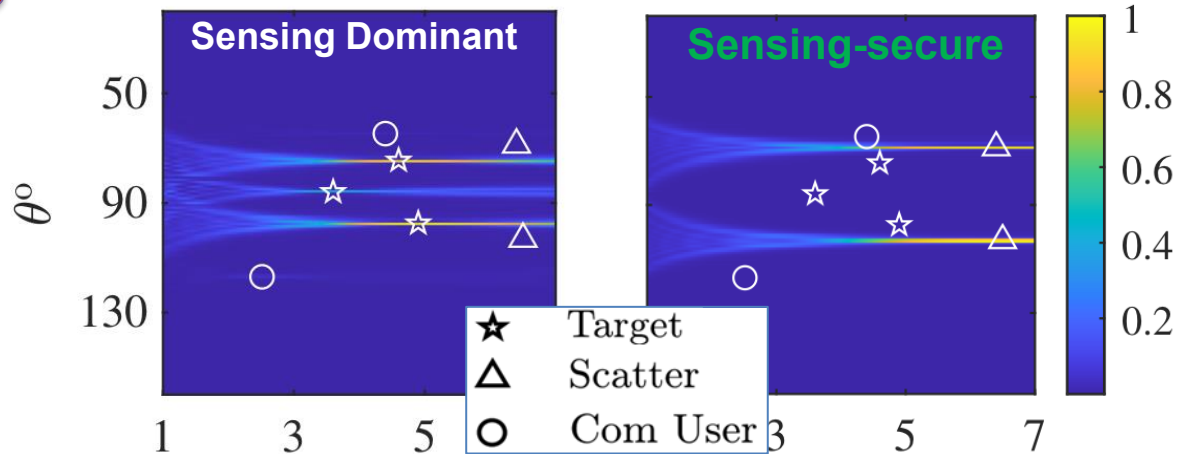

Capon Spectrum

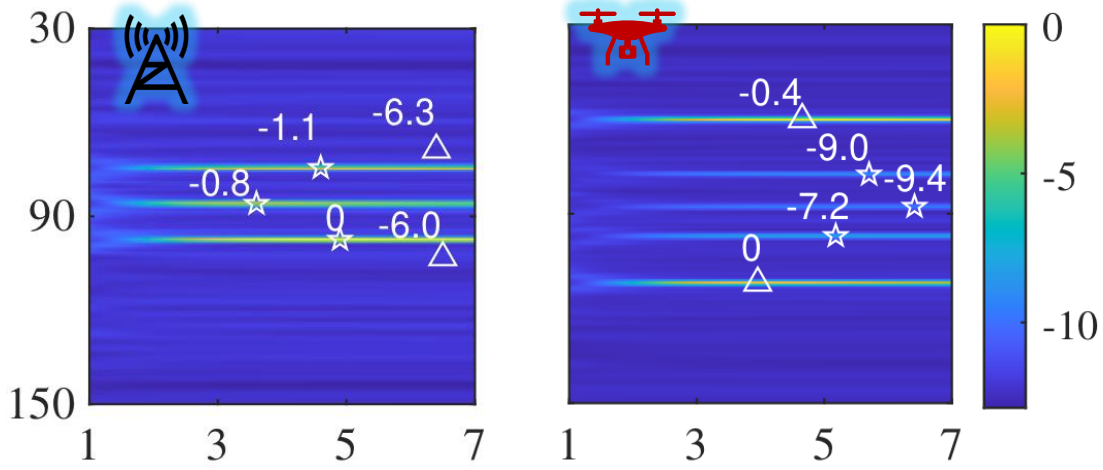

J. Chen, C. Masouros, "Sensing security in integrated sensing and communication system", patent filed

J. Chen, X. Lei, K. Meng, K. Han, Y. Zhang, C. Masouros, A. Petropulu, "Sensing Security in Near-Field ISAC: Exploiting Scatterers for Eavesdropper Deception", IEEE Trans. Signal Process., under review.

Angle RMSE and RCRB

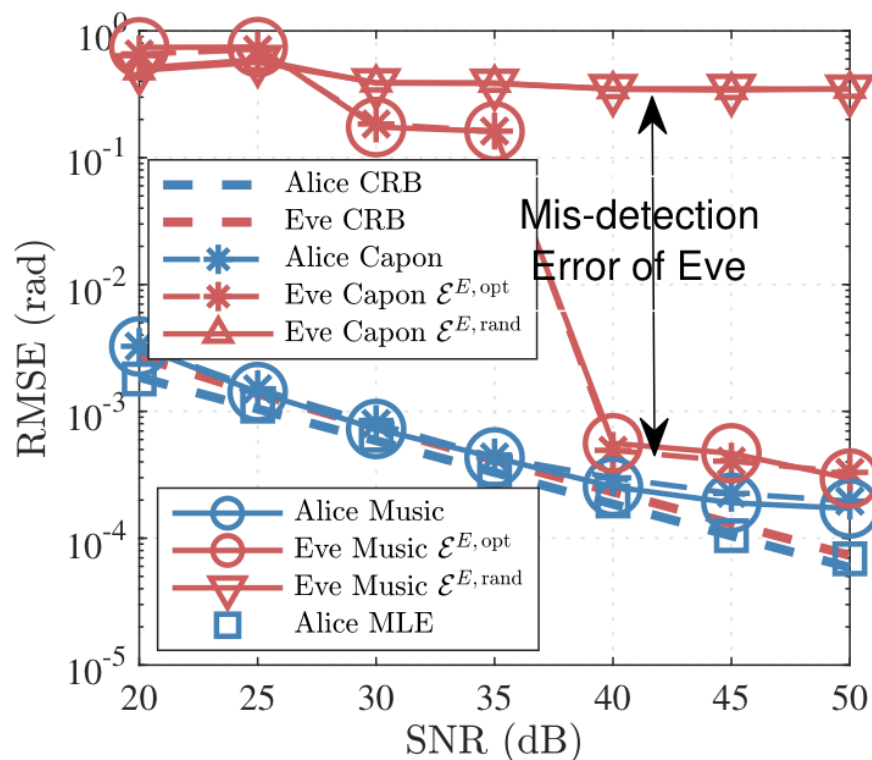

Range RMSE and RCRB

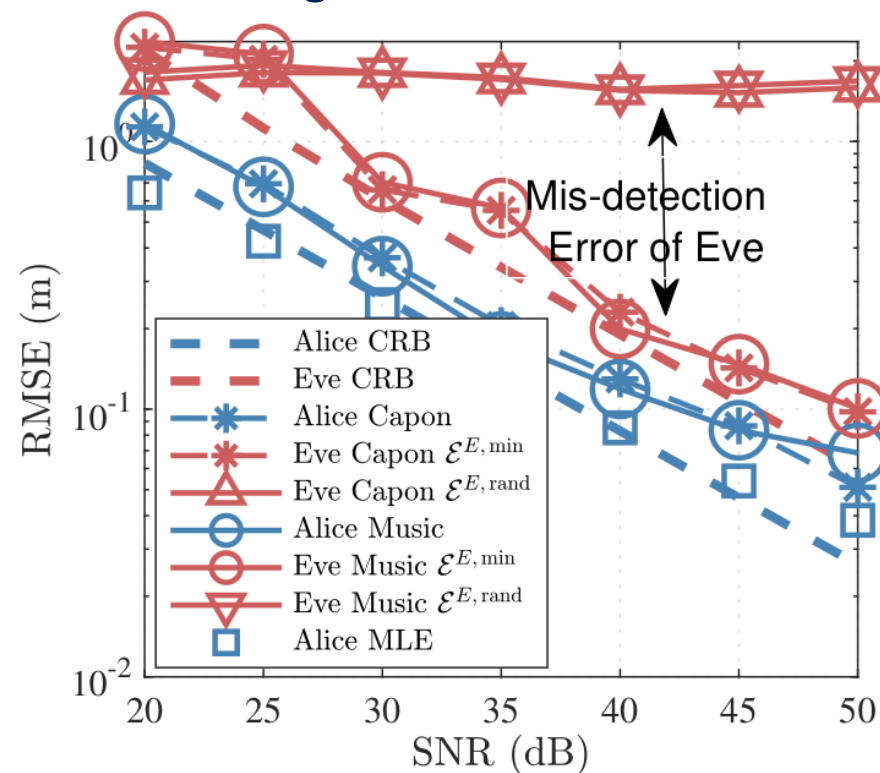

- Alice can remove known scatterers
- Significant mis-detection can be achieved when Eve cannot recognize targets from scatterers in both angle and range estimations.

J. Chen, C. Masouros, "Sensing security in integrated sensing and communication system", patent filed

J. Chen, X. Lei, K. Meng, K. Han, Y. Zhang, C. Masouros, A. Petropulu, "Sensing Security in Near-Field ISAC: Exploiting Scatterers for Eavesdropper Deception", IEEE Trans. Signal Process., under review.

Thank you

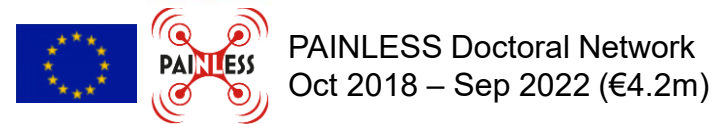
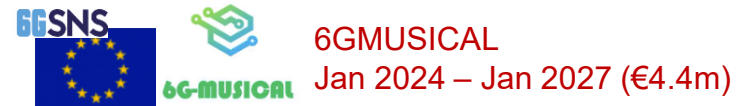
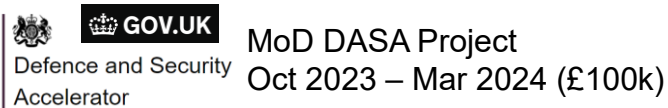
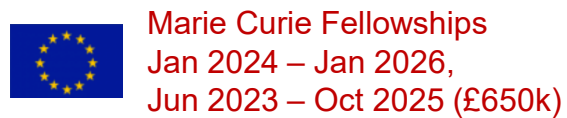
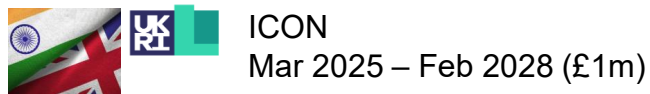

Overviews

1. F. Liu, Y. Cui, C. Masouros, J. Xu, T. X. Han, A. Hassanien, Y. Eldar, S. Buzzi, "Integrated Sensing and Communications: Towards Future Dual-functional Wireless Networks", IEEE Journal on Sel. Areas Comms., vol. 40, no. 6, pp. 1728-1767, June 2022
2. Z. Wei, F. Liu, C. Masouros, N. Su, A. Petropulu, "Towards Multi-Functional 6G Wireless Networks: Integrating Sensing, Communication and Security" IEEE Wireless Comms Mag., vol. 60, no. 4, pp. 65-71, April 2022
3. J. A. Zhang, F. Liu, C. Masouros, R. W. Heath, Z. Feng, L. Zheng, A. Petropulu, "An Overview of Signal Processing Techniques for Joint Communication and Radar Sensing" IEEE Jour. Selected Topics Sig Proc, vol. 15, no. 6, pp. 1295-1315, Nov. 2021
4. F. Liu and C. Masouros, "A Tutorial on Joint Radar and Communication Transmission for Vehicular Networks - *Parts I - III*", IEEE Commun. Lett., vol. 25, no. 2, pp. 322-336, Feb. 2021 - *EiC Invited Paper*
5. F. Liu, C. Masouros, H. Griffiths, A. Petropulu, and L. Hanzo, "Joint Radar and Communication Design: Applications, State-of-the-art, and the Road Ahead", IEEE Trans Commun., vol. 68, no. 6, pp. 3834-3862, June 2020. – *EiC invited paper - The 2023 IEEE ComSoc Stephen O. Rice Prize*

Book

6. F. Liu, C. Masouros, Y. Eldar, "Integrated Sensing and Communications", 2023 edition Springer

Radar-Comms Coexistence

7. F. Liu, A. Garcia, C. Masouros, and G. Geraci, "Interfering Channel Estimation in Radar-Cellular Coexistence: How Much Information Do We Need?", IEEE Trans. Wireless Comm., vol. 18, no. 9, pp. 4238-4253, Sept. 2019
8. F. Liu, C. Masouros, A. Li, T. Ratnarajah and J. Zhou, "MIMO Radar and Cellular Coexistence: A Power-Efficient Approach Enabled by Interference Exploitation", IEEE Trans. Sig Proc, vol. 66, no. 14, pp. 3681-3695, July 2018,
9. F. Liu, C. Masouros, A. Li, and T. Ratnarajah, "Robust MIMO Beamforming for Cellular and Radar Coexistence," IEEE Wireless Commun. Lett., vol. 6, no. 3, pp. 374-377, June 2017.
10. F. Liu, L. Zhou, C. Masouros, A. Li, A. Petropulu, "Dual-functional cellular and radar transmission: Beyond co-existence", IEEE SPAWC 2018

Dual-functional Radar-Communication

11. I. Valiulahi, A. Salem, C. Masouros, "Net-Zero Energy Dual-Functional Radar and Communication Systems", IEEE Trans. Green Comms. Networks, under review
12. M. Al-Jarrah, E. Alsusa, C. Masouros, "A Uniform Performance Framework for Integrated Sensing-Communications based on KL-Divergence", IEEE Trans. Wireless Comms, under review
13. X. Jing, F. Liu, C. Masouros, Y. Zeng, "ISAC from the Sky: UAV Trajectory Design for Joint Communication and Target Localization", IEEE Trans Wireless Comms, under review
14. A. Salem, C. Masouros, F. Liu, D. Lopez Perez, "Rethinking Dense Cells for Integrated Sensing and Communications: A Stochastic Geometric View" IEEE Trans. Wireless Comms., under review
15. F. Liu, Y. Liu, A. Li, C. Masouros, Y. Eldar, "Cramér-Rao Bound Optimization for Joint Radar-Communication Design", IEEE Trans. Sig. Proc., vol. 70, pp. 240-253, 2022
16. L. Chen, F. Liu, W. Wang, and C. Masouros, "Joint Radar-Communication Transmission: A Generalized Pareto Optimization Framework", IEEE Trans. Signal Process., vol. 69, pp. 2752-2765, 2021.
17. F. Liu, C. Masouros, T. Ratnarajah, and A. Petropulu, "On Range Sidelobe Reduction for Dual-functional Radar-Communication Waveforms", IEEE Wireless Commun. Lett., 2020.
18. F. Liu, C. Masouros, A. Li, H. Sun, and L. Hanzo, "MU-MIMO Communications with MIMO Radar: From Co-existence to Joint Transmission", IEEE Trans. Wireless Commun., vol. 17, no. 4, pp. 2755-2770, April 2018
19. F. Liu, L. Zhou, C. Masouros, A. Li, W. Luo, and A. Petropulu, "Toward Dual-functional Radar-Communication Systems: Optimal Waveform Design," IEEE Trans Signal Process., vol. 66, no. 16, pp. 4264-4279, Aug. 2018. - **The 2023 IEEE ComSoc Stephen O. Rice Prize**

Hardware-efficient DFRC Transmission

20. I. Valiulahi, A. Salem, C. Masouros, F. Liu "Antenna Selection for Energy-Efficient Dual-Functional Radar-Communication Systems", IEEE Wireless Comms. Let., vol. 11, no. 4, pp. 741-745, April 2022
21. O. Dizdar, A. Kaushik, B. Clerckx, C. Masouros, "Rate-Splitting Multiple Access for Joint Radar-Communications with Low-Resolution DACs", IEEE Trans. Coms., vol. 15, no. 6, pp. 1332-1347, Nov. 2021
22. N. Babu, A. Kosasih, C. Masouros, E. Bjornson, "Symbol-Level Precoding for Near-Field ISAC", IEEE Comms Let., in press

Secure DFRC Transmission

23. N. Su, F. Liu, C. Masouros, “Sensing-Assisted Eavesdropper Estimation: An ISAC Breakthrough in PHY Security”, IEEE Trans. Wireless Comms., under review
24. N. Su, F. Liu, Z. Wei, Y. Liu, C. Masouros, “Secure Dual-Functional Radar-Communication Transmission: Exploiting Interference for Resilience Against Target Eavesdropping”, IEEE Trans. Wireless Comms., vol. 21, no. 9, pp. 7238-7252, Sept. 2022
25. N. Su, F. Liu, and C. Masouros, “Secure Radar-Communication Systems with Malicious Targets: Integrating Radar, Communications and Jamming Functionalities”, IEEE Trans. Wireless Comm., vol. 20, no. 1, Jan. 2021
26. Z. Wei, F. Liu, C. Masouros, N. Su, A. Petropulu, “Towards Multi-Functional 6G Wireless Networks: Integrating Sensing, Communication and Security” IEEE Wireless Comms Mag., vol. 60, no. 4, pp. 65-71, April 2022
27. J. Zou, C. Masouros, F. Liu, S. Sun, “Securing the Sensing Functionality in ISAC Networks: An Artificial Noise Design”, IEEE Trans. Veh. Tech., in press

Vehicular DFRC Transmission

27. Z. Du, F. Liu, W. Yuan, C. Masouros, Z. Zhang, G. Caire, “Integrated Sensing and Communications for V2I Networks: Dynamic Predictive Beamforming for Extended Vehicle Targets”, IEEE Trans. Wireless Comms., in press
28. W. Yuan, F. Liu, C. Masouros, J. Yuan, D. W. K. Ng, and N. G. Prelcic, "Bayesian Predictive Beamforming for Vehicular Networks: A Low-Overhead Joint Radar-Communication Approach", IEEE Trans. Wireless Commun., vol. 20, no. 3, pp. 1442-1456, March 2021
29. F. Liu, W. Yuan, C. Masouros, and J. Yuan, “Radar-assisted Predictive Beam-forming for Vehicular Links: Communication Served by Sensing”, IEEE Trans. Wireless Commun., vol. 19, no 11, pp. 7704-7719, Nov. 2020
30. W. Yuan, F. Liu, C. Masouros, J. Yuan, and D. W. K. Ng, "Joint Radar-Communication Based Bayesian Predictive Beamforming for Vehicular Networks", IEEE RadarConf 2020, Special Session on Multi-Function Spectral System Co-Design – [Invited paper](#)
31. C. Aydogdu, F. Liu, C. Masouros, H. Wymeersch, and M. Rydström, "Distributed Radar-aided Vehicle-to-Vehicle Communication", IEEE RadarConf 2020.

DFRC experiments

33. T. Xu, F. Liu, C. Masouros, I. Darwazeh, “An Experimental Proof of Concept for Integrated Sensing and Communications Waveform Design”, IEEE Open Journal ComSoc, IEEE Open Journal of Comms. Soc., vol. 3, pp. 1643-1655, 2022
34. M. Temiz, N. Peters, C. Horne, M. Ritchie, C. Masouros, “An Experimental Study of Radar-Centric Transmission for Integrated Sensing and Communications”, IEEE Transactions on Microwave Theory and Techniques, vol. 71, no. 7, pp. 3203-3216, July 2023

Network-Level DFRC

35. K. Meng, C. Masouros, F. Liu, “Network-Level Integrated Sensing and Communication: Interference Management and BS Coordination Using Stochastic Geometry” IEEE Trans. Wireless Comms. In press
36. K. Meng, C. Masouros, A. Petropulu, L. Hanzo, “Network-level Cooperative ISAC: Opportunities and Challenges” IEEE Comms. Mag. In press
37. A. Salem, K. Meng, C. Masouros, F. Liu, D. Lopez Perez, “Rethinking Dense Cells for Integrated Sensing and Communications: A Stochastic Geometric View” IEEE Open Journal ComSoc vol. 5, pp. 2226-2239, 2024
38. K. Meng, K. Han, C. Masouros, A. Petropulu, L. Hanzo, “Network-Level ISAC: Performance Analysis and Optimal Antenna-to-BS Allocation” IEEE Trans Wireless Comms, under review
39. K. Meng, C. Masouros, A. Petropulu, L. Hanzo, “Cooperative ISAC Networks: Performance Analysis, Scaling Laws and Optimization” IEEE Trans Wireless Comms, under review

Multi-cell DFRC Beamforming

40. N. Babu, C. Masouros, C. Papadias, Y. Eldar, “Precoding for Multi-Cell ISAC: from Coordinated Beamforming to Coordinated Multipoint and Bi-Static Sensing”, IEEE Transactions on Wireless Comms, in press
41. L. Jiang, K. Meng, M. Temiz, J. Hu, C. Masouros, “Federated Learning-Based Cooperative Beamforming for Multicell Integrated Sensing and Communications Systems”, IEEE Trans. Wireless Comms, under review

Distributed DFRC

42. K. Han, C. Masouros, et. al, “Coherent vs Non-Coherent Distributed Integrated Sensing and Communications”, IEEE Trans. Wireless Comms., under review

Self-Synchronisation for ISAC

43. X.Y. Wang, H. Zhai, S. Yang, C. Masouros, A. Zhang, “Windowing Optimization for Fingerprint-Spectrum-Based Passive Sensing in Perceptive Mobile Networks”, IEEE Trans on Comms., in press
44. X.Y. Wang, S. Yang, J. Zhang, P. Zhang, C. Masouros, “Clutter Suppression, Time-Frequency Synchronization, and Sensing Parameter Association in Asynchronous Perceptive Vehicular Networks”, IEEE Jour. Sel Areas Comms., in press
45. K. Han, K. Meng, C. Masouros, “Over-the-Air Time and Frequency Synchronization for Distributed Integrated Sensing and Communications” IEEE Trans Wireless Comm, under review